

28 May 2010

Frequency Regulation for
Software Defined Radio and Cognitive Radio

Frequency Regulation for Software Defined Radio and Cognitive Radio

Final Report

28 May 2010

Authors and contributors:

Dr Roland Brugger

Reinhard Gorol

Jan Outters

Alexander Schertz

This document was prepared under commission to the German Federal Ministry of Economics and Technology.

Copyright notice

This document and all of its contents are protected by copyright legislation. All rights reserved. Unless otherwise agreed, this document or its contents may not be reproduced, translated, distributed, recorded on microfilm, transmitted, displayed, published, or stored in and/or processed in electronic systems without the prior written permission of the Institut für Rundfunktechnik. The copyright notice, trademarks and other notifications may not be modified or removed.

Table of content

Table of content.....	III
Executive Summary	1
1. Introduction.....	8
2. Definition of Cognitive Radio and Software Defined Radio.....	10
3. General and Frequency-independent Aspects of Software Defined Radio and Cognitive Radio.....	11
3.1 Software defined radio.....	11
3.1.1 Fundamentals	11
3.1.2 Types of software defined radio	13
3.1.3 Parameters of software defined radio and their technical limitations.....	14
3.1.4 Advantages of software defined radio.....	18
3.1.5 Potential problems with software defined radio	22
3.1.6 Services that use software defined radio.....	22
3.2 Cognitive radio	24
3.2.1 Fundamentals	24
3.2.2 Elements of observation and orientation.....	25
3.2.3 Elements of planning and learning	35
3.2.4 Advantages of cognitive radio	36
3.2.5 Potential problems and other aspects to be considered with cognitive radio ...	40
3.2.6 Services that use cognitive radio	40
4. Analysis of Specific Frequency Bands	45
4.1 Methodology description	45
4.2 Frequency bands allocated to the mobile service.....	46
4.2.1 880-915 / 925-960 MHz	46
4.2.2 790-862 MHz	50
4.2.3 1920-1980 / 2110-2170 MHz	51
4.2.4 2500-2690 MHz	52
4.3 Frequency bands allocated to the broadcasting service	54
4.3.1 470-790 MHz	54
4.4 Frequency bands allocated to the fixed-satellite service.....	57
4.4.1 3400-4200 MHz	57
4.5 Other frequency bands	60
5. Analysis of the Pros and Cons of Potential Regulatory Changes.....	72
5.1 Technical conclusions from the analysis of specific frequency bands.....	72
5.1.1 Mobile service	72
5.1.2 Broadcasting service	73
5.1.3 Fixed-satellite service	73

5.1.4	Radio astronomy service and other passive services	74
5.1.5	Aeronautical radionavigation service	74
5.2	Changes to the Radio Regulations for software defined radio	75
5.3	Changes to the Radio Regulations for cognitive radio	75
5.4	Changes to the Radio Regulations for cognitive pilot channels	75
5.5	Optional regulatory changes to foster cognitive radio	76
6.	Conclusions	77
Annex 1		
	Examples of Devices Based on Software Defined Radio.....	80
Annex 2		
	Potential Hazards of Air Interface Reconfiguration.....	82
Annex 3		
	Examples of Precognitive Systems.....	84
Annex 4		
	Example Derivation of the Technical Constraints for the Use of Cognitive Radio Technology with Vertical Sharing	85
Annex 5		
	Interference Mitigation Techniques.....	98
Annex 6		
	Discussion of the Technical Restrictions on Cognitive Radio	99
	Bibliography.....	100
	List of Abbreviations	108

Executive Summary

Cognitive radio (CR) and software defined radio (SDR) are currently widely discussed topics because the use of these technologies offers greater flexibility in frequency use and more efficient (and in part automated) management of spectrum resources.

A CR system (CRS) is defined as follows by ITU-R:¹ *“A radio system employing technology that allows the system to obtain knowledge of its operational and geographical environment, established policies and its internal state; to dynamically and autonomously adjust its operational parameters and protocols according to its obtained knowledge in order to achieve predefined objectives; and to learn from the results obtained.”*

In particular, a CR system uses spectrum occupancy information (such as frequency use) to adapt its transmission parameters (frequency, transmit power, etc.).

For the use of CR technology, a differentiation must be made between two basic forms of coexistence between different services in the same band:

- **Vertical sharing:** Ressource sharing by applications with different regulatory status (primary or secondary allocation to a single service or different services). For example, Programme Making and Special Events (PMSE) applications may utilise CR technology in order to avoid interfering with another application already active in a band, such as broadcasting.
- **Horizontal sharing:** Ressource sharing by applications with the same regulatory status (both applications, primary or secondary). In this case, both services may utilise CR technology.

ITU-R provides the following definition of software defined radio (SDR):⁷ *“A radio transmitter and/or receiver employing a technology that allows the RF operating parameters including, but not limited to, frequency range, modulation type, or output power to be set or altered by software, excluding changes to operating parameters which occur during the normal pre-installed and predetermined operation of a radio according to a system specification or standard.”*

Ideally, all signal processing is implemented in software so that all parameters can be altered as desired during operation.

SDR and CR systems are to be understood as technical implementations of devices of any radio communication service, which apply SDR or CR technology.

¹ Report ITU-R SM.2152, Definitions of Software Defined Radio (SDR) and Cognitive Radio System (CRS)

SDR yields very significant advantages for CR, since increased transmission parameter flexibility – a logical consequence of SDR – results in correspondingly increased potential adaptability in a specific radio environment. Therefore, it is to be expected and is regarded as necessary that CR technology will always be based on SDR.

The question whether the use of CR and SDR systems requires changes to the ITU Radio Regulations is on the agenda of the World Radiocommunication Conference in 2012². This agenda item is based on the recognition that CR and SDR systems enable expanded and possibly additional uses in already utilised frequency bands and thus allow better efficiency to be achieved. On the other hand, it is also necessary to ensure that the various services do not lead to unacceptable mutual interference.

In order to answer this question, it is first necessary to examine the **aspects of CR and SDR independent of any specific frequency bands**.

SDR is already being used more and more, such as in mobile services. Flexibility in the selection of signals and frequencies, flexible interference cancellation, and the possibility of aggregating spectrum from different bands according to availability give SDR many advantages with regard to coexistence and efficiency. In addition, the costs of device development and manufacturing drop when changes require only software modifications and the same hardware can be produced in larger volume. Development cycles before market launch are shortened and device development risks are reduced.

The potential usage of **SDR** is limited by technical factors. Large bandwidths and high signal flexibility lead to higher power consumption due to the necessary modules, such as A/D converters. A bandwidth of 500 MHz is presently realistic for portable devices. It can be expected that reasonably priced SDR devices will be optimised for specific frequency bands with a bandwidth of several hundred megahertz, or for a specific group of frequency bands with a corresponding total bandwidth. Larger bandwidths can be expected in the future as a result of technological progress.

CR in the full sense of the previously stated definition is not yet used at present. However, basic cognitive techniques that can be characterised as ‘pre-cognitive’ are already being used with short range devices (e.g. WLAN) in order to reduce interference. Inability to achieve full interference avoidance is accepted as part of the price of this approach.

Up to now, the coexistence of multiple users has primarily³ been made possible by the utilisation of specific spatial, temporal or frequency partitioning. If several spectrum users must be taken into account, when several users in overlapping regions make use of the same

² Agenda Item 1.19 (<http://www.itu.int/ITU-R/study-groups/docs/rwp5a-WRC-11-AI-1-19.doc>): ‘...to consider regulatory measures and their relevance, in order to enable the introduction of software-defined radio and cognitive radio systems, based on the results of ITU-R studies, in accordance with Resolution 956’

³ Except devices using pre-cognitive technology

channel, this is not implemented using automated methods, but instead always requires human involvement (frequency allocation, engineering, planning, coordination, etc.). The coexistence of multiple users can be regulated automatically with CR, thereby allowing a more frequency efficient use of spectrum, but at the same time much more complex and more compute-intensive. Consequently, in the future CR technology will allow individual frequency bands to be shared by different services to a much greater extent than up to now.

Acquisition of information on the radio environment ('cognition') is of fundamental importance for the optimisation of frequency use. Three methods can be used for this:

- Spectrum sensing (individual and cooperative sensing): The CR devices sense the radio environment. In the simplest case, this consists of a field strength measurement by the CR device.
- Using central geodatabases (without pilot channels): The CR devices acquire information on the radio environment (such as potentially usable frequencies in a particular band) from a database to which they connect using an infrastructure (such as mobile telecommunication systems) not specifically created for this purpose.
- Using pilot channels (cognitive pilot channels, CPC): Information acquisition via an infrastructure created for this purpose. Central databases can also be used.

The following table gives an overview of the pros and cons of these three options:

	Pros	Cons
Sensing	very economical because no separate infrastructure is necessary	fully satisfactory interference avoidance is technically impossible
Geodatabase	no separate local infrastructure is necessary	separate database infrastructure is necessary; certain amount of delay involved in updating the database on the server and in the devices
Pilot channel	speed comparable to mobile telecommunication time frame; short-term resource management possible	separate database and network infrastructure is necessary, which makes this the most expensive option

Tabelle 1-1: Overview of pro and con

From an analysis of developments up to now and the anticipated future development of CR technology, it can be concluded that none of these methods by themselves will be able to lead to complete detection of the radio environment. Instead, it will be necessary to rely on a combination of several methods. All of these methods involve non-negligible technical and/or infrastructure effort and expense.

The following issues must be discussed with regard to the **analysis of individual frequency bands**:

- How can the radio environment be described?
- Are SDR and CR technologies already being used, and what trend can be expected?
- Are horizontal sharing and vertical sharing based on CR technology possible or meaningful?
- Are changes to the Radio Regulations or other regulatory changes necessary or advantageous?

Firstly, this frequency-related analysis indicates that **SDR** is already being used for many radio services and will be used more and more in the future. The transition times may differ from one service to the other.

Since all of these uses exclusively involve the implementation of technology in existing systems, there is no need for changes to the Radio Regulations, and in particular no need for the creation of a new service definition. Thus, that there are no new services, new allocations in the Radio Regulations are not necessary.

Furthermore, the analysis indicates that **CR technology** is already being used in the mobile services in **horizontal sharing**. This is not presently the case with aeronautical radio-navigation services, but it can already be anticipated that this technology will be used and formulated in future standards. The use of such technologies for horizontal sharing in the broadcasting service, earth exploration-satellite service and radio astronomy service is highly unlikely due to the nature of these services.

The analysis shows that for the application of CR technology in horizontal sharing there is no need for changes to the frequency regulations at any level, whether international or national.

The application of CR technology by services subject to **vertical sharing** with regard to primary services differs widely for the various services, depending on the characteristics of the primary service:

- **Broadcasting Service:** In principle, resource sharing with CR services is possible. However, it would require considerable effort and expense (such as geo-localisation with databases, sensing and power limitation) to limit interference to an acceptable level.
- **Aeronautical Radionavigation Service:** Although sharing with application using CR technology in the bands concerned is in principle possible from a technical perspective, it is prohibited by the potential safety risks. A CPC specifically for these bands could be transmitted, but there would be low benefit in comparison to the cost. In addition, protecting the CPC against the exertion of influence by unauthorised parties would be a substantial security issue.

- Radio Astronomy Service: As this (passive) use occurs in isolated locations and coexistence with other applications is conceivable with sufficient spatial decoupling and transmission restrictions, in principle vertical sharing based on geo-localisation using databases would be possible. Nevertheless, opening of this band is not advisable in light of the restrictions and the limited size of the available frequency bands.
- Fixed Satellite Service (FSS): Resource sharing with other applications by means of cognitive technology is conceivable, since interference can be avoided by means such as a database and suitable constraints. The sub band considered in the analysis (3400–3800 MHz) has already been released for broadband wireless access (BWA) with the restriction that full protection of the FSS service must be assured. This protection could be automated by using cognitive technology under the conditions mentioned above.
- Mobile Service: As most systems in the considered frequency bands already employ digital technology or will do so in the near future, the adoption of cognitive technology by existing (or new) applications will be possible in principle. With a limitation to spectrum sensing, the interference level can basically be expected to increase significantly with a large number of additional users. Simple spectrum sensing is adequate, if only users with low transmit power are allowed and a certain interference level is acceptable to mobile service operators without cognitive technology.

If instead interference avoidance has high priority, geo-localisation using databases could assure significantly better freedom from interference but would allow the full use of only a fraction of the resources made available by dynamic use of the spectrum utilised by a mobile service. In this case, it is an open question whether the potential of the thus additionally usable spectrum would justify the cost of establishing a database.

Interference mitigation and maximum resource exploitation could best be achieved in such cases by using a CPC to allocate the resources. However, this would incur considerable cost if the CPC is implemented independently and information about the radio environment must be acquired by the CPC itself. As spectrum usage information is already available in the mobile telecommunication infrastructure, it would appear more appropriate to operate the CPC as an integrated component of the mobile service infrastructure. A direct in-band solution, where the CPC is operated directly in the band concerned, seems reasonable.

The analysis shows that the application of CR technology in vertical sharing with regard to primary services does not justify any changes to the Radio Regulations. To the extent that the applications concerned do not claim protection from other services and are not allowed

to interfere, they can be introduced based on Article 4.4 of the Radio Regulations⁴ without any need for additional allocations.

Nevertheless, the establishment or amendment of ITU-R recommendations, such as recommendations on the configuration of technical parameters, could foster the emergence of the broadest possible worldwide market. Specifications laid down by the CEPT are necessary to make trans-European regulation of these technical parameters binding.

Since the parameters of the applications to be protected are country-specific, the maintenance of the entries in the geo-databases and harmonisation of the results for either horizontal or vertical sharing should take place at national level.

In addition to resource sharing between CR devices and non-CR devices, the issue of resource sharing among CR devices is relevant. For all services, where CR devices are to be introduced for vertical sharing, it is fact that although in principle sensing can be used to avoid mutual interference between CR devices and is the easiest option to implement, a certain probability of interference will occur. Using only a central geodatabase with localisation (without pilot channels) allows for relatively static resource management only, since continuous updating of the database through generally used data infrastructures (such as mobile telecommunication) in real time would cause too much data traffic. This problem could be solved with the aid of CPCs that allow for fast data transmission, although constructing a suitable infrastructure would require considerable effort and corresponding costs.

A specific question of agenda item 1.19 of WRC-12 is whether **cognitive pilot channels** need to be dealt with separately in the Radio Regulations. Resolution 956 [COM6/18] (WRC-07) referenced by agenda item 1.19 mentions that some studies indicate the need for an internationally harmonised CPC with a bandwidth of less than 50 kHz to support access and connectivity.⁵ The analysis of specific frequency bands shows that CR does not necessarily need to be operated by means of a CPC. An independent CPC would be costly. If to be implemented, it would make more sense to build it on top of an existing infrastructure and use the available spectrum.

For technical and economic reasons, worldwide harmonisation of the parameters of such CPC appears to be unrealistic under current conditions. Regulatory measures at the Radio Regulations level are not necessary, at least not at present.

⁴ 'Administrations of the Member States shall not assign to a station any frequency in derogation of either the Table of Frequency Allocations in this Chapter or the other provisions of these Regulations, except on the express condition that such a station, when using such a frequency assignment, shall not cause harmful interference to, and shall not claim protection from harmful interference caused by a station operating in accordance with the provisions of the Constitution, the Convention and these Regulations.'

⁵ 'The World Radiocommunication Conference (Geneva, 2007), considering ... j) that some studies indicate a possible need for a worldwide harmonized cognitive supporting pilot channel with a bandwidth less than 50 kHz, whilst other studies indicate that the availability of a database could support access and connectivity, and therefore support the use of these systems, ...'

However, it would certainly be possible to develop ITU-R recommendations on this matter. Although such recommendations are not binding, which for example means that various technical options can be chosen, they command international attention and encourage the industry as well as administrative bodies to use the available options. Elements or options of the ITU-R recommendations can originate from binding options at the European level (ECC decisions).

When sufficiently broad adoption of the European options has occurred outside Europe, treatment at the level of the Radio Regulations could be considered in future.

In summary, the following recommendations may be made:

1. The ITU Radio Regulations shall remain untouched by the application of CR and SDR, since in their current form they allow sufficient scope for the presently foreseeable potential and meaningful expansion of the parallel use of frequency bands by multiple services or applications.
2. ITU-R recommendations would be advantageous for fostering the broadest possible worldwide markets:
 - a. Relevant study groups could develop recommendations for the use of SDR and CR in applications and their impact on the services within their scope of responsibility.
 - b. With regard to vertical sharing, relevant study groups could develop recommendations based on CR technology for the protection of the services within their scope against other services,
 - c. Study Group 1 could amend ITU-R Recommendation SM.1538 (Short Range Devices) to include the appropriate applications and their corresponding parameters.
 - d. If necessary, relevant study groups could formulate recommendations for CPC parameters if future technological developments indicate the necessity.
3. Nevertheless, it is advisable to take frequency policy measures at other levels. For instance, an ECC recommendation or an ECC decision promoting the use of cognitive technology for short range devices in order to achieve more efficient use of the frequency bands (e.g., in band 2.4–2.483 GHz).
4. CR technology does not open new frequency bands, but the bands already in use can be used more effectively in order to avoid spectrum scarcity. Fostering the introduction of this technology would be especially worthwhile for Programme Making and Special Events (PMSE) and Broadcasting.

1. Introduction

Cognitive radio (CR) and software defined radio (SDR) are currently widely discussed topics, especially because they enable a desirable degree of flexibility in the usage of the frequency spectrum and allow more efficient (and in part automated) management of spectrum resources. The following agenda item (1.19) was adopted at World Radio Conference WRC-07 with regard to the regulation of CR and SDR:

‘to consider regulatory measures and their relevance, in order to enable the introduction of software-defined radio and cognitive radio systems, based on the results of ITU-R studies, in accordance with Resolution 956 (WRC-07);’

WRC-07 requested the administrations to study whether regulatory measures with regard to the use of CR and SDR systems are necessary; in order to properly accommodate these two technological developments. If necessary, these measures shall be adopted by WRC-12 and the Radio Regulations shall be amended accordingly.

The purpose of the present study is to answer the following questions:

- Are changes to the Radio Regulations necessary?
- If changes to the Radio Regulations were not necessary, would it nevertheless be advantageous to make other changes at the ITU-R level?
- Should the use of both systems be restricted to specific frequency bands in order to allow operation of ‘old’ and ‘new’ services and applications with as little interference as possible, or can they be integrated into other bands, or should the full spectrum (or large parts of the spectrum) be made available to them?
- Is it possible to define blanket restrictions to which SDR and CR systems and devices should or must comply?
- Are there any inherent restrictions to the spectrum that can be used by SDR or CR due to physical constraints?
- If restriction of SDR or CR to specific frequency bands were necessary, which frequency bands would be suitable, and would international or at least regional harmonisation be necessary for these bands?

In order to answer these questions, it is first necessary to determine how the currently available services have evolved up to now and how they will continue to evolve in the future in interaction with CR and SDR. For this purpose, it is first necessary to define CR and SDR (**Section 2**). This is followed by a general overview of the capabilities and limitations of current implementations of SDR and CR and the anticipated future developments and concepts in this area (**Section 3**).

The next section (**Section 4**) presents an analysis of specific frequency bands from the following perspectives:

- How can the current radio environment be described?
- Are SDR and CR technologies already being used, and which trends can be expected?
- Is the introduction of additional users based on CR technology with horizontal sharing possible and/or realistic?
- Are changes to the Radio Regulations or other regulatory changes necessary or advantageous?

The frequency bands are arranged by type of service to allow conclusions to be drawn for these services.

The analysis of the pros and cons of potential regulatory changes is described in **Section 5**.

Finally, in **Section 6** the results of the analysis of these frequency bands are used to answer the questions mentioned above. In addition, recommendations are stated with regard to whether changes to the regulations would be beneficial, and if so, which changes should be made.

2. Definition of Cognitive Radio and Software Defined Radio

As part of the preparatory activities for WRC-12, an initial milestone was reached with a common definition of CR and SDR. According to ITU-R [ITU-R_SM.2152], SDR and CR systems are defined as follows:

Software defined radio (SDR): *'A radio transmitter and/or receiver employing a technology that allows the RF operating parameters including, but not limited to, frequency range, modulation type, or output power to be set or altered by software, excluding changes to operating parameters which occur during the normal pre-installed and predetermined operation of a radio according to a system specification or standard.'*

Cognitive radio system (CRS): *'A radio system employing technology that allows the system to obtain knowledge of its operational and geographical environment, established policies and its internal state; to dynamically and autonomously adjust its operational parameters and protocols according to its obtained knowledge in order to achieve predefined objectives; and to learn from the results obtained.'*

Radio Reconfigurable Systems (RRS) is additionally defined as a collective term for CR and SDR in the context of ETSI activities related to this subject (see [ETSI_SUMMARY]).

These definitions formed the basis for this study.

According to Mitola [MITOLA], CR is divided into six phases according to the intended system behaviour: observe, orient, plan, learn, decide, and act. A CR device adapts its internal model of the outside world to its external cognition and uses this information to optimise its transmission parameters according to operational requirements. Only a few of these phases have actually been implemented in practice up to now. This is discussed in more detail in the next section.

Based on the ITU-R definitions and Mitola's concepts, SDR can be regarded as a means for the implementation of CR (an 'enabler'), whereby 'acting' (i.e. sending or receiving freely definable signals resulting from the internal model) is the most elementary objective of CR.

3. General and Frequency-independent Aspects of Software Defined Radio and Cognitive Radio

This section discusses general aspects of SDR and CR that are frequency independent. Frequency-specific aspects are considered in **Section 4**, 'Analysis of Specific Frequency Bands'.

3.1 Software defined radio

3.1.1 Fundamentals

3.1.1.1 Analogue and digital signal processing

Every transmit or receive device can be regarded in simplified form as consisting of three modules:

- a man-machine interface (human interface) for entering and outputting data;
- a processing unit that processes the data – data processor;
- an air interface module for the transmission and reception of data and signals.

The air interface module is significant for using the radio spectrum. It may be implemented with discrete components, such as filters, transistors, transformers and so on, where every change in signal type must be realised by means of a specific analogue circuit.

Many types of signal processing are already implementable in digital technology. With a receiver, this involves digitising the received signal in a stage of the signal processing chain, which means that the analogue signal is sampled. After this, the signal itself is no longer processed, but instead its digitised values (samples).

On the transmitter side, up to a certain stage of the signal processing chain the samples are processed or calculated according to the defined air interface, and then converted into an continuous signal.

This digital signal processing may be performed by integrated circuits (application specific integrated circuits / ASICs), but it may also be performed by programmable components (programmable logic devices / PLDs), whose operating mode can be modified, or by software-controlled digital signal processors (DSPs).

In both of the latter two cases, the processing may be altered as desired by means of software. This is called SDR because the processing of the samples is no longer determined by fixed electronic components, but instead the processing rules (the signal processing) may be altered as desired under software control. The larger the digital component of the signal processing chain, the more flexibly the air interface may be configured.

SDR is already used in many products. Some examples are presented in **Annex 1**.

3.1.1.2 Aspects of signal digitisation

Analogue to digital or digital to analogue conversion is a key element in digital signal processing. In this section, we only intend to discuss the aspects relevant to this study. Readers interested in more information are referred to other sources, such as the basic reference *Signale und Systeme* [SUS].

According to the Nyquist theorem, a signal must be sampled at twice the rate of its highest frequency in order to allow reliable reconstruction of the signal afterwards.

Digitisation of a signal generates periodic images of the signal in the spectral domain. The spacing of these images corresponds to the sampling frequency. If the signal to be digitised has a larger bandwidth than the sampling frequency, overlaps (aliasing) occur in the spectral domain.

Figure 3.1 illustrates the various possibilities for signal digitisation in the frequency domain.

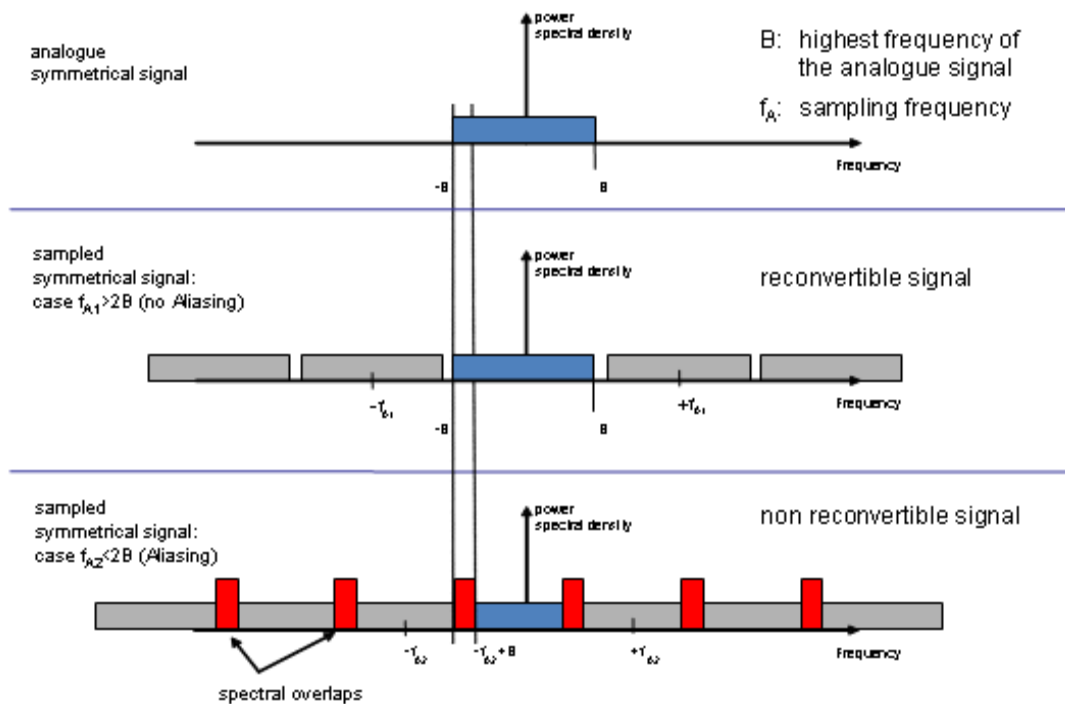

Figure 3.1: Signal digitisation in the frequency domain

With suitable selection of band limiting and undersampling (i.e. selecting a sampling frequency that is less than half the maximum signal frequency), the signal can be converted to a lower frequency range without generating any spectral overlaps.

This means that in order to digitise a signal either an analogue to digital converter with a suitable sampling rate must be chosen or the bandwidth of the signal must be limited appropriately. Accordingly, the properties of an SDR device depend on the choice of the A/D converter.

A similar rule applies to the reconstruction of an analogue signal from the samples.

3.1.2 Types of software defined radio

The nature of the SDR device determines the requirements on the hardware and the resulting advantages and disadvantages. To a first approximation, SDR devices may be classified as described below.

3.1.2.1 Ideal software defined radio

The most general-purpose form of SDR is the form in which the transfer to the digital system occurs after the input stage, or in the case of a transmit device, in which signal processing is purely digital up to the RF unit (a module consisting of the receiver input stage or transmitter output stage and filters).

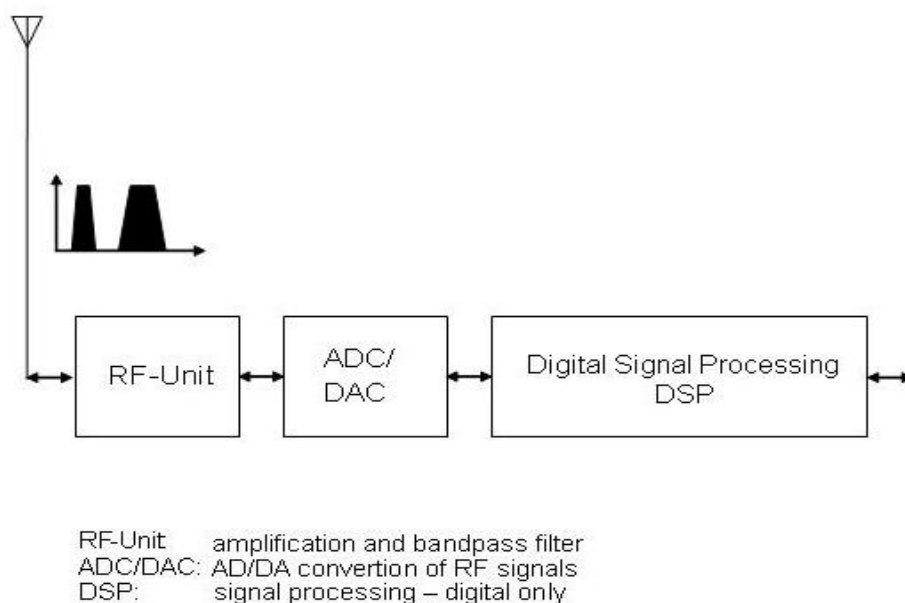

Figure 3.2: Schematic diagram of an ideal SDR

Figure 3.2 shows a simplified schematic diagram of an ideal SDR. In an ideal system, after the antenna signal has been amplified and filtered (in a receiver), it is fed directly to an A/D converter and processed digitally from that point onward. In a transmitter, the output signal passes through a D/A converter and is then filtered, amplified, and fed to the antenna.

The advantage of an ideal SDR is that the entire process is frequency agile, which means that it can be used for any frequency band. The only limiting factor is the sampling rate of the analogue to digital converter, which restricts the maximum signal frequency.

On the other hand, the disadvantages of an ideal SDR are:

- HF signals must be processed directly by the A/D converter (ADC), which means that ADCs with very wide bandwidth are required. The requirements on the analogue to digital converter are essentially determined by the interference signals that cannot be filtered out by the RF unit (bandpass filter and amplifier).

- Generally speaking, the power consumption of the analogue to digital converter increases with increasing sampling rate.

To mitigate the disadvantages, the signal can be mixed down to an intermediate frequency or to the baseband in the HF stage and the resulting signal can then be further processed. However, this requires additional bandpass filters to filter out interference signals.

Depending on the application, it is also possible to concentrate only on the high-frequency portion or only on the low-frequency signal processing, as described below.

3.1.2.2 High-frequency software defined radio (HFSDR)

High-frequency SDR enables high frequency agility, which means that large continuously tuneable frequency bands may be used. In the focus of an HFSDR is the flexibility of the HF parameters, such as bandwidth, intermediate frequency and transmit power. At relatively high frequencies, the previously mentioned difficulties with the analogue to digital converter arise and restrict the maximum frequency.

Higher frequencies must be filtered out to avoid aliasing. This is achieved by using a preselection filter, which is a filter circuit placed between the antenna and the receiver in order to restrict the frequency band. Preselection filters may be tuneable and thus usable over a range of frequencies, or they may be designed to operate at a fixed frequency. The higher complexity of such systems makes them more suitable for specific applications and less suitable for inexpensive consumer devices.

3.1.2.3 Baseband software defined radio (BBSDR)

In contrast to HFSDR, the primary concern with BBSDR is flexibility with regard to the signal form instead of the greatest possible usable frequency range. Here the HF portion of the device is implemented conventionally with discrete components. The rest of the signal processing is performed in the baseband by software, which allows a wide variety of signal forms to be processed.

3.1.3 Parameters of software defined radio and their technical limitations

SDR devices may fundamentally be characterised by four components:

- antenna;
- RF unit;
- A/D converter or D/A converter;
- digital signal processing.

In the remainder of this section, these components are described and their technical limitations and possible future development trends are estimated.

3.1.3.1 Antennas

Antennas with compact dimensions for mobile devices are designed as resonant antennas. The usable frequency range of these antennas is relatively narrow. Several antennas are therefore used for multiband reception, although they have relatively narrow-band characteristics, especially at low frequencies (e.g. 70 MHz bandwidth below 1 GHz). The antenna is a critical limiting factor for the maximum bandwidth of an SDR device.

Antenna restrictions do not play such a significant role with stationary SDR, since less compact antennas may be used in such applications. To achieve greater bandwidth, switchable antennas may be used, or an antenna with higher maximum gain may be used to ensure that the required minimum gain is obtained even at the edges of the bandwidth concerned.

3.1.3.2 RF unit

The RF unit, consisting of the receiver input stage or transmitter output stage and filters, also has a significant effect on the system parameters.

Wideband receiver input or transmitter output stage

The receiver input or transmitter output stage forms the link between the antenna and the signal processing stage. Its principal element is an amplifier, which determines the primary characteristics of this component: its linearity over a relatively wide frequency band, its power consumption, and its noise figure.

Modern terminals generally have a linear bandwidth of several hundred megahertz with an acceptable noise figure. Further technological progress is necessary to enable a constant noise figure over significantly larger bandwidths.

Filters

A preselection filter is used at the receive end to restrict the bandwidth and interference from strong signals ('near-far' problem, which means that a strong interference source is located near a receiver intended to receive a signal from a source farther away; see also **Section 4.2.5**). This filter limits the flexibility of frequency band selection, and it causes losses. The preselection filter is often omitted for these reasons, leaving the antenna to perform this task.

Filtering may be used at the transmit end to suppress nonlinearities. However, here as well filtering is often omitted to maximise efficiency and reduce costs. In such cases, the antenna provides the filtering function.

However, the antenna cannot be used for supplementary filtering if it has a large bandwidth for reception or transmission, since this always restricts the dynamic characteristics. Here there is a conflict between the objectives of good receiver dynamic characteristics and high frequency agility.

3.1.3.3 A/D or D/A converter

As mentioned in **Section 3.1.1**, the A/D or D/A converter is a significant determining factor for the bandwidth that can be processed by SDR and therefore has a direct impact on the flexibility of SDR devices. The relevant parameters are the spurious-free dynamic range (SFDR), the signal to noise ratio (SNR), the power consumption, and the maximum bandwidth.

SFDR and SNR as parameters for receiver dynamic characteristics

The SFDR specifies the maximum dynamic range within which harmonics (intermodulation products) remain below the noise level. The SNR is affected by the sampling rate of the A/D converter. The SNR and SFDR determine how well the receiver performs in the presence of strong received interference signals. The larger the SFDR and the SNR, the more robust the receiver is with respect to strong interference signals.

Maximum bandwidth and power consumption

Here the maximum bandwidth means the maximum bandwidth that an SDR device is able to process. There is a correlation between power consumption and maximum bandwidth: the greater the bandwidth, the greater the power consumption.

A survey of currently available A/D converters specifically optimised for SDR shows that bandwidths of around 500 MHz can be achieved for mobile and handheld devices. Here it was assumed that a power consumption of around 100 mW is still acceptable.

In addition, it can be seen that larger bandwidths are already possible, but at the price of higher power consumption (up to 1 W). For this reason, SDR with larger bandwidths can currently be used only for portable or stationary devices, but not for mobile (handheld) devices. Here it can be expected that larger bandwidths with significantly lower power consumption will be achievable in the coming years. This will enable more efficient utilisation of the available battery power and therefore smaller devices.

The same considerations apply to D/A converters.

3.1.3.4 Digital signal processing

Processors serve to process digital data. They perform the actual demodulation, cancel interference, sense the transmission channel, and perform signal detection. With SDR, signal processing is performed by FPGAs, SIMDs, DSPs, or a multipurpose CPU.

Multipurpose CPU

Fundamentally, digital signal processing can always be performed by a CPU.

The advantage of this approach is that it provides maximum flexibility for signal processing.

On the other hand, the disadvantages are:

- relatively high power consumption (on the order of several watts);
- many operating elements remain unused (causing unnecessary power consumption);
- sequential operation processing: complex operations require a correspondingly large number of clock cycles, so a suitably high clock rate must be used, which causes higher power consumption.

DSPs

Digital signal processors (DSPs) are processors specifically optimised for signal processing. Their power consumption is somewhat less than that of multipurpose CPUs. Otherwise, they have the same advantages and disadvantages as multipurpose CPUs.

FPGAs

Field programmable gate arrays (FPGAs) are another implementation option for signal processing, although they require a programming device for reconfiguration. FPGAs consist of a large number of programmable logic components.

Their advantages relative to DSPs and CPUs are:

- lower development costs;
- easier correction and extension (reconfigurable), but with less flexibility;
- simple operations can be performed in parallel.

Their disadvantages relative to DSPs and CPUs are:

- lower clock rates (currently available range up to 600 MHz; typically 20–250 MHz);
- lower logic density (around 10 times larger footprint than ASICs in the same technology);
- a group of logic components must be used for every operation;
- lower shielding against electromagnetic waves due to larger surface area;
- reconfiguration requires reprogramming.

Extensions to DSPs and CPUs

Instead of increasing the processing power of a CPU or DSP for more complex signal processing by using a higher clock rate (with correspondingly higher power consumption), specific operations may be performed by supplementary modules integrated on the chip.

One option is to use single instruction multiple data (SIMD) devices. SIMD devices are array processors or vector processors. They are designed to execute similar calculations quickly and can be used to process several incoming or available input data streams simultaneously.

Another option is to use hardware acceleration. Complex operations such as turbocode, Viterbi coding and so on are often offloaded this way.

The advantage of this is that complex operations can be executed without imposing a significant additional load on the CPU or DSP. This results in reduced power consumption

and allows the CPU to be used for other complex tasks, such as video decoding. However, it reduces signal processing flexibility because many computing operations are predefined and unalterable.

3.1.3.5 Characteristic parameters of software defined radio

In summary, it can be said that the capacity of software defined radio is determined by the filters, antennas, A/D and D/A converters and signal processing components that are used.

The maximum achievable bandwidth is determined by the A/D and D/A converters, the antenna, the filters and the receiver input or transmitter output stages. The power consumption increases with increasing bandwidth.

The complexity of the signal processing and the degree of waveform flexibility also affect the power consumption.

A compromise between power consumption and flexibility can be achieved by using SIMD devices and hardware acceleration.

Overall, the power consumption of the devices increases with increasing flexibility (with regard to frequency agility and signal forms), with the result that SDRs can be produced at reasonable prices only if they are optimised for a specific frequency band or set of frequency bands with a width of several hundred megahertz. Increasingly larger bandwidths can be expected in the future.

3.1.4 Advantages of software defined radio

Up to now, the introduction of new systems has been hampered by the need to find a suitable frequency band that allows the best possible conditions for acceptable coexistence with other systems. SDR makes it possible to adapt devices more flexibly to various types of frequency usage environments. This can be achieved by means of the features of SDR described below.

3.1.4.1 Flexible signal selection

With flexible signal selection, it is possible to select a type of signal that enables coexistence with existing applications. However, it must be borne in mind that the transmission efficiency of the SDR device is usually reduced by this adaptation.

For example, the future mobile telecommunication system LTE based on the GSM parameters allows dynamic exclusion of specific carriers to enable coexistence with GSM (narrowband pulsed system). The capacity of the LTE system is reduced as a result of this adjustment.

A device can alter its transmission parameters in real time in order to achieve better coexistence with other spectrum users. Adjustments to the transmit power, modulation or usage schedule are suitable for this purpose. Different signal forms can also be selected for use in order to simplify separation of the useful signal from an interference signal. For

example, the SDR device could select a narrowband signal if the other signal is broadband. To illustrate this, we describe here an example of spectral shaping in an OFDM SDR system (see **Figure 3.3**). Orthogonal frequency division multiplexing (OFDM) is a multiple access method in which the data is transmitted on multiple narrowband carriers. Here an SDR system based on OFDM uses the channels not needed by two narrowband primary systems and excludes the channels used by the primary systems. An actual example of this form of coexistence between a narrowband system and a broadband system is the combination of wire-based powerline communication (broadband) and amateur radio (narrowband) in the same frequency band.

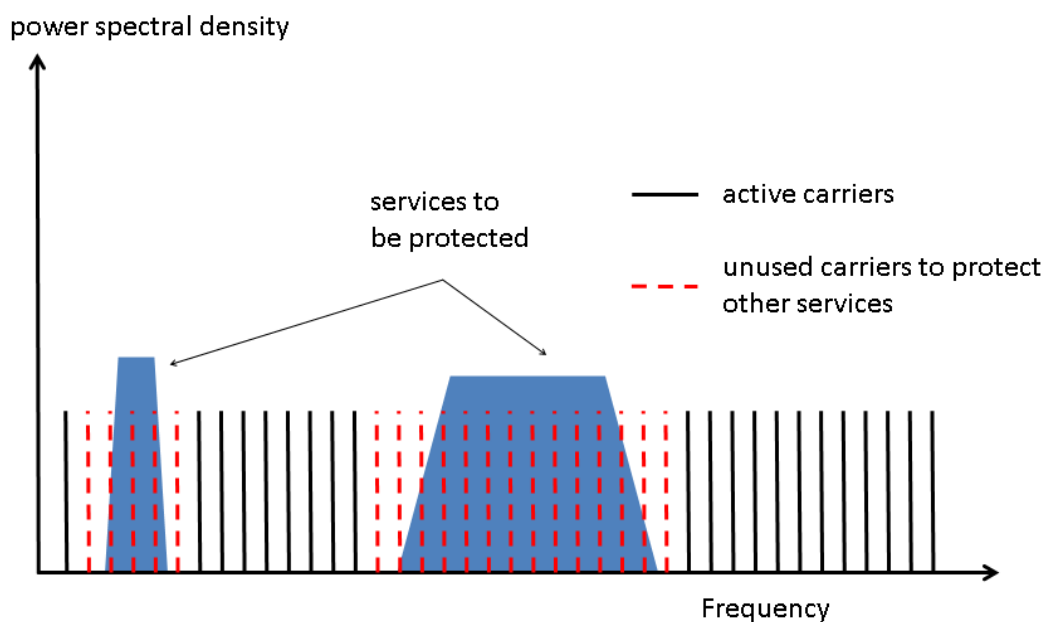

Figure 3.3: Carrier exclusion scheme in an OFDM system

Adjacent channel interference is usually a problem when directly adjacent channels are used. This can be avoided by using suitably steep spectrum masks and receive filters, but this increases the complexity of the signal processing and accordingly the computation effort. Potential remedies come at the expense of the desired energy efficiency.

Finally, SDR offers opportunities for the flexible use of interference mitigation techniques. Although these techniques are not new in principle, only with SDR can they be used without changes to the hardware of the specific usage environment (interference conditions, utilised frequency band, etc.), which simplifies shared spectrum usage.

3.1.4.2 Flexible interference cancellation

Due to the fact that signal processing is controlled by software with SDR, a variety of methods for signal estimation and interference mitigation may be used flexibly and in combination. Signal estimation and noise mitigation methods are always optimised for a

particular signal form in existing devices lacking SDR technology, with the consequence that changes to coexisting applications or systems may prevent further use of these devices.

3.1.4.3 Dynamic adaptation of the air interface

At present only a few parameters are varied for dynamic adaptation of the air interface (also called the 'radio access technology'): the modulation (more sophisticated or more robust), the frequency, and the transmit power.

In the future, it is conceivable that all parameters of the air interface could be optimised dynamically according to the radio environment and the needs of individual applications. For example, this could consist of changing from a wideband signal to a narrowband signal, or from an OFDM signal to a WCDMA signal, in order to achieve simpler interference management under certain conditions. WCDMA (wideband code division multiple access) utilises spread-spectrum technology to distribute the signal energy over a wider bandwidth. SDR is a prerequisite for this sort of flexibility, and suitable algorithms for parameter selection must be developed.

3.1.4.4 Flexible frequency selection

Up to now, devices have often been restricted in terms of usable frequencies. SDR can provide access to more frequency bands, thereby making significantly more otherwise unused frequencies potentially available. This also eliminates the need to develop specific devices for the temporary use of particular frequency bands. Frequency agility is essentially limited by the extent to which wideband antennas with acceptable efficiency can be designed and produced and the achievable bandwidths of the transmitter output and receiver input stages (see **Section 3.1.3** in this regard).

3.1.4.5 Spectrum aggregation

As a result of increasing spectrum usage, it is becoming more and more difficult to find large frequency bands that are still available. At the same time, the demands of rising data rates make larger bandwidths indispensable, despite increased efficiency. SDR allows simultaneous processing of a relatively large bandwidth, so several unused band segments with relatively large gaps can be combined to form a virtual carrier (spectrum aggregation). This has the further advantage that the increased frequency diversity counteracts fading. Adequate bandwidth of the SDR device is a prerequisite for this (see **Section 3.1.3** in this regard).

3.1.4.6 Additional advantages

In addition to increased spectral efficiency, SDR systems provide the advantages of lower device development and manufacturing costs and higher spectrum usage flexibility.

Developing a new SDR implementation of a technology already in widespread use is more costly than a fully mature hardware implementation of the same technology. In the case of relatively small markets, new devices and evolving air interfaces, the use of SDR yields many advantages for device development and manufacturing, as described below.

3.1.4.7 Shorter time to market

SDR makes it possible to reconfigure the air interface without any need for direct contact with the device ('over the air' reconfigurability), so signal processing and air interface algorithms can be refined and upgraded after the devices are already on the market.

Development cycles for air interfaces or interface implementation generally take several months because the full functionality must be present and adequately tested before market launch.

Devices with restricted capabilities and simplified algorithms can reach the market faster and are subsequently upgradable over the air. For example, algorithms for interference mitigation can be introduced in stages. With the SDR approach, devices can gradually be equipped with increasingly complex implementations of the air interface while still maintaining a stable implementation in each stage.

However, this advantage of SDR has the limitation that the device must be sufficiently mature at the market launch time to achieve customer satisfaction.

Over the air reconfigurability allows the introduction of new technologies and new devices to be accelerated. Instead of carrying out product development and market launch in sequence, the two processes can be performed in parallel.

3.1.4.8 Reduced device development risks

SDR devices differ almost exclusively in their software, so they can be used for many different applications. If a device does not achieve the expected market acceptance, the devices can be reconfigured for other applications by means of software and can be marketed elsewhere (in other sectors). This reduces the investment risk for device development and production.

3.1.4.9 Reduced start-up investment for devices with innovative air interfaces

Already now, devices are usually based on software at the system level. It can be seen that significantly more companies (known as 'fabless companies') are involved in product development at this level caused by the financial investment necessary to develop products is lower than when individual components must be produced as separate products. A similar evolution can be expected for SDR at the air interface level.

3.1.4.10 Larger production volumes reduce production costs

Up to now, efforts to reduce product costs have focused on creating the largest possible global market for specific devices. With the introduction of SDR, the hardware components can be used for a wider variety of applications. In the ideal case, the air interfaces are only differentiated by the software, so substantially larger production volumes are possible, and the critical minimum volume for a particular market can be achieved more quickly.

3.1.4.11 In-field implementation or bug fixing for specific functions

If some standard functions are not implemented in a device or changes are made to the standard, with SDR they can be implemented in devices already in the field.

3.1.4.12 Lower development costs with flexible devices

When different frequencies are used for a particular service in different countries, up to now it has been necessary to develop and produce devices adapted to these requirements. For example, according to a survey by OFCOM cited in CEPT Report 22 [CEPT_Report22], in the case of mobile telecommunication devices the minimum market that must be attained to cover the development costs is four countries with small populations or 100 million consumers. SDR devices can be adapted dynamically and therefore can be used for different frequencies and systems, so they can counteract this effect.

3.1.5 Potential problems with software defined radio

Many advantages of SDR resulting from its reconfigurability are described in **Section 3.1.4**. However, this also harbours risks.

Reconfiguration may have an adverse effect on the behaviour of devices. They may become unusable, or they may become sources of interference to the devices of other users in the frequency band concerned.

In addition, there are problems associated with the implementation of the software transfer for updating the software of the SDR device. They are described in **Annex 2**.

3.1.6 Services that use software defined radio

This section provides an overview of the services in which existing applications already use SDR in the sense of the ITU-R definition.

Amateur service

Many applications in the amateur service (such as digital data transmission and amateur television) are based on elements of SDR. Reconfigurability is in principle present if the user adjusts the transmission parameters, although according to the previously stated definition a feature of SDR is software configurability.

Mobile service

Many applications (private mobile radio and public safety services) already use SDR platforms for the implementation of existing systems. In the case of the public mobile service (GSM, UMTS and LTE), the power, modulation and frequency are already varied under software control. However, the individual devices are tied to a specific system by dedicated components.

Fixed service

The state of implementation of SDR in the fixed service corresponds to the state of implementation in the mobile service.

Broadcasting service

Implementations using SDR (DRM, DxB, etc.) have already been realised in the broadcasting service. There is increasing use of SDR.

Reconfigurable SDR does not exist, but it could arise in the future. This requires the definition of reconfigurability by suitable standards.

Fixed satellite service (FSS)

The state of implementation of SDR in FSS corresponds to the state of implementation in the broadcasting service.

Mobile satellite service (MSS)

SDR is already being used for reconfigurable military applications. Implementations of terminals for MILCOM and SATCOM military systems and the Inmarsat system are already available.

Aeronautical radionavigation service

SDR is not used in the aeronautical radionavigation service. Implementations of SDR technology are conceivable in the future.

Radio astronomy service

Reception facilities using SDR are already in operation for radio astronomy (see [ASSA]).

Earthexploration-satellite service

The state of implementation of SDR in the Earth -exploration satellite service corresponds to the state of implementation in the radio astronomy service.

3.2 Cognitive radio

3.2.1 Fundamentals

Up to now, coexistence of multiple users has primarily⁶ been made possible by means of specific spatial, temporal or frequency partitioning schemes. When several spectrum users must be taken into account, such as when several users in overlapping regions use the same channel, this is not achieved by automated methods, but instead always requires human involvement. CR automates this, and in addition, it learns to optimise these automated actions based on predefined goals.

In the use of CR technology, a distinction must be made between two basic forms of coexistence between different services in a single frequency band:

- **Vertical sharing:** Ressource sharing by applications having different regulatory status. For example, Programme Making and Special Events (PMSE) with low priority may utilise CR technology in order to avoid restricting or interfering with a broadcasting service.
- **Horizontal sharing:** Ressource sharing by applications having similar regulatory status. In this case, both services may utilise CR technology. For example, they could be cellular systems.

The form of sharing (vertical or horizontal) describes the relationship between two services, each of which may be primary or secondary. This formally yields eight potential combinations, of which only some are actually meaningful:

- Two primary services or two applications of primary services may share resources based on horizontal or vertical sharing.
- Two secondary services or two applications of secondary services may share resources based on horizontal or vertical sharing. Vertical sharing between the two secondary services is based on their relationship with a primary service.
- A primary service and a secondary service may share resources based on vertical sharing.

In order to answer the question posed in this study as to whether regulatory measures are necessary for the introduction of CR technology, it is sufficient to examine the basic form of sharing (vertical or horizontal) in each case. Concrete examples are described in the analysis of specific frequency bands in **Section 4**.

Based on the ITU definition, we can distinguish two functions with CR: perception (cognitive abilities) and the corresponding action (response).

⁶ Except devices using pre-cognitive technology

If a CR device has information about its surroundings (cognition), it can adapt itself accordingly. This is regarded as action. Some elements of this are described in this section. These elements are largely realized by using SDR. The extent and combination of the elements depend on the degree of implementation of the SDR technology.

According to Mitola [MITOLA], the behaviour of CR is characterised by 'observe, orient, plan, learn, decide, and act'. 'Observe', 'orient', 'plan' and 'learn' can collectively be regarded as elements of cognition, while 'decide' and 'act' are regarded as elements of action. Elements of action may be regarded as SDR properties.

Below we provide an overview of the elements of cognition. The elements of observation and orientation are examined in **Section 3.2.2**, while the elements of planning and learning are examined in **Section 3.2.3**. Some examples of the elements of action are choosing a transmission protocol or choosing a frequency band. Selected examples are discussed in **Section 3.2.4**.

The core aspects of the CR concept are inclusion of the temporally or spatially variable radio environment and autonomous adaptation to this environment by the devices (transmitters and receivers) of a radio application.

Some radio applications are by nature not candidates for CR functionality. The transmitter may be fundamentally unsuitable because it cannot be manipulated, it may be fundamentally or practically impossible to detect the radio link of another application, or it may not be possible to implement the necessary feedback channel.

In a vertical sharing relationship, such an application may assume the role of the privileged service to which the other application adapts by means of CR technology. A radio application of this sort cannot enter into a horizontal sharing relationship in which both applications mutually adapt to each other, which means that both must have sufficient CR functionality. It is therefore unsuitable for horizontal sharing.

Some examples of this are radio astronomy and radar applications, where little if any influence can be exerted on the 'transmit facility', and the broadcast service, which (at least in its traditional form) does not have a feedback channel and which, due to its large range, is not able to detect the local radio links of other applications.

In the remainder of this study, reference to these circumstances is made by means of a reference to the 'nature' of these services.

3.2.2 Elements of observation and orientation

3.2.2.1 Sensing

Sensing is a process in which the CR device measures and detects the signals of other users at its reception site and analyses the occupancy of the spectrum. In the simplest case, this consists making a field strength measurement. More advanced systems draw conclusions

regarding the signal type and the sort of protection it requires, determine the transmitter location, and estimate the potential receivers and the duty cycle.

In the ideal case, the sensing component of the CR device is able to continuously and flawlessly analyse the entire spectrum. However, in practice sensing is restricted by the physical properties of wave propagation as described below.

Wave propagation statistics (the 'hidden node' problem)

Information about a propagation path, and with it the measured signal (sensing), can only be acquired statistically. The received signal level varies, even if the distance to the signal source remains constant. This variation results from superimposed slow and fast fading. Both forms of fading may have considerable amplitude. They have different physical causes. Slow fading results from obstacles in the propagation path, such as buildings, walls and so on. Fast fading results from the vector addition of several wavefronts originating from nearby or distant objects as a result of the diffraction or reflection of the originally transmitted signal, which arrive at the receiver with different phases (multipath propagation).

Fading can occur even with a constant environment, since weather conditions, wind and moving objects also affect propagation. It is thus possible for the CR device making the signal measurement to be in a 'trough' of the signal radiated by the non-cognitive device. If the sensing sensitivity is too low, no signal will be seen and the frequency band will be falsely regarded as being currently unused. To avoid this, the sensitivity of the sensor must be greater than the average level of the signal to be detected (it must exceed this level by a suitable (fading) margin) so that the signal of another service can be detected with sufficient reliability. Additional margins (positive or negative) relative to the average level of the signal to be detected under free space conditions at a specific height must be provided to allow for building penetration loss (as a statistical quantity) and the height of the receiver or the receive antenna. These margins must be added to or subtracted from the sensitivity of the sensor so that even strongly attenuated or nearly extinguished signals can still be detected. Variances of around 40 to 60 dB may occur, depending on whether supplementary height and/or building penetration loss margins are taken into account.

If the sensor is in a location where the signal is so attenuated or extinguished that it cannot be detected, sensing will yield incorrect results. This is called the 'hidden node' problem.

Various approaches can be used to increase the detection probability. The following approaches may be used to compensate (partially) for the hidden-node effect:

- **Antenna diversity:** This partially compensates for fast fading.
- **Cooperative sensing:** A group of sensors may be used in place of sensing by a single device, since it is unlikely that several devices will be located in a radio dead zone at the same time. The data exchange protocols, radio environment modelling and decision optimisation algorithms for this method must still be developed. In this

case a binary decision 'used/unused' is not adequate; instead it is necessary to acquire, convey and take into account the characteristics of the various uses. The complexity of the entire process increases with the number of users and the observed bandwidth. An overview of this approach can be found in e.g. [TH-Karlsruhe].

- **Increased sensitivity:** The sensitivity of the device may be increased by the amount necessary to compensate for the losses. For example, if the typical minimum receive power specified for a non-CR device is -84 dBm, the sensor must have a sensitivity of -124 to -144 dBm. However, this verges on the limits of what is technically feasible at present, as described below (see '**Finite sensor sensitivity**')

Finite sensor measuring bandwidth

Tuners require a certain amount of time for tuning, which means that tuning to a specific channel takes a certain amount of time. This causes the scan time to increase when many channels are scanned. In addition, a minimum observation time is necessary to allow a signal to be analysed. This is essentially dependent on the signal structure.

This can be remedied by increasing the measuring bandwidth or reducing the frequency range. Increasing the measuring bandwidth reduces the number of iterations necessary to sample the entire frequency spectrum and increases the potential for dynamic spectrum usage. However, increased bandwidth comes at the price of more complex signal processing. In addition, constant spectrum sampling requires the continual operation of a supplementary receive unit, which in turn consumes power.

Finite input dynamic range of the sensor

A strong signal adversely affects the sensitivity of the sensor to adjacent frequencies. The larger the frequency range to be sensed, the larger is the probability that strong signals will be present. There is therefore a contradiction between high sensor sensitivity and large measuring bandwidth.

Finite sensor sensitivity

It is technically possible with optimised signal processing to achieve detection thresholds significantly lower than the noise level. For example, signals below the noise level can be detected by using a correlator that can distinguish the signal from the noise. **Table 3.1** provides an example for the detection of DVB-T signals.

There is a relationship between the length of the time window for FFT analysis and the required SNR. The 'pilots' of OFDM symbols are used for detection. The probability of detecting these pilots increases with the ratio of the measuring time to the symbol duration.

Sensing time [μ s]	Number of antennas	Detection probability	Protection ratio [dB]	Sensitivity [dBm]
17.92		1.0	-21	-121
1.12	2	1.0	-12	-112

Table 3.1: Examples of achievable sensitivities (source: [HUAWEI_802.22])

The required high sensitivity (in part due to the hidden node problem) represents the limit of what is feasible with the current state of technology, as has been shown by the initial testing of white space devices in the USA [FCC_WHITE_SPACES].

Summary

If we compare the sensor sensitivity values necessary for reliable detection (see ‘Wave propagation statistics’ above) with currently achievable values (taking the detection of DVB-T signals as an example; see **Table 3.2**), it can be seen that the sensitivity of CR devices is not sufficient. In practice, CR devices based exclusively on sensing cannot flawlessly detect spectrum occupancy. For this reason, the term ‘estimation’ is used in connection with sensing. Nevertheless, sensing-only devices are already being used extensively (see **Annex 3, ‘Precognitive Systems’**). To compensate for their low detection capability, their transmit power is highly restricted to reduce their potential for causing interference. In addition, these applications are not operated together with services sensitive to interference in the same frequency range.

3.2.2.2 Geo-localisation and databases

When databases and geo-localisation are used, CR devices determine their spatial position and then acquire information on the local radio environment (such as potentially usable frequencies in a particular region) from one or more databases to which they connect using an infrastructure (such a mobile telecommunication system) not specifically created for this purpose. Under the current conditions for linking to mobile telecommunication networks, it can be assumed that this process involves a certain amount of delay. The time span between a change in usage and updating the database must also taken into account by the CR device. A database is more suitable for adapting to stationary users than for dynamic management of spectrum resources for a group of CR devices. Dynamic updating of accesses would have to occur within the duration of a typical frame interval (as usual with mobile telecommunication systems) in the millisecond range. Guaranteed latencies on this order are not conceivable in the short to medium term with existing infrastructures, so it would be necessary to use sensing in combination with databases.

A database containing information on all existing frequency uses and complying with the requirements of CR does not presently exist. Generating and coordinating such a database would require a large amount of effort. In addition, continual updating would be necessary

because spectrum usage changes constantly, even with primary services that do not use devices with cognitive properties.

Geo-localisation

Geo-localisation can be achieved either by **localisation** (using the cell data of existing networks) or by **orientation** (conventional navigation, such as with GPS or Galileo). If cell data is used, an existing infrastructure must be utilised. For example, a conceivable option would be to use the cell data of a mobile telecommunication system. This presumes that the signals are available and can be received. Another consideration with localisation is that the precision is limited by the cell density.

If an orientation system is used instead, a precision in the range of a few metres can be achieved. However, orientation data signals can usually be received only outside buildings, which means that orientation systems are not a viable option for indoor use.

All in all, a combination of localisation and orientation should be specified in order to always achieve the necessary geo-localisation precision.

Database models

Negative database or positive database

Here a **negative database** is understood to mean a database containing information on the devices or stations within the service area that require protection. All protected users are entered into this database.

In this case, the resulting constraints (protection areas and available frequencies) must be calculated by the CR device itself.

On the one hand, the negative database method simplifies the processing and updating of the database, so updating is in principle limited to a purely administrative process (without any engineering).

On the other hand, with this approach it is up to the device to perform the necessary calculations and take the necessary decisions. The individual calculation and decision rules may be stored in a separate part of the database.

However, behaviour rules (policy) may vary locally or nationally, which means that in theory there may be many different policies. They can also be amended, thereby increasing the complexity of the database and, as a result, the complexity of the CR devices that wish to access it.

In addition, the CR device must be able to quick calculations of the availability of resources at any time, which consumes processing capacity and causes corresponding delays.

The situation in border areas could be problematic. In such situations, the device would need to be able to decide which technical protection criteria to apply. These criteria could vary from one country to the next, for example due to differing usage concepts.

Existing databases (e.g. EFIS⁷) are based on this 'negative' concept because it is the easiest to implement.

A **positive database** holds information on the available resources. The calculations are performed and the decisions are taken before the data is entered.

A disadvantage here is that database maintenance is significantly more complex than with a negative database and updating may involve a certain amount of delay. In the ideal case, the calculations and decisions are automated to enable fast updating. In the present perspective, determining the available resources involves human intervention (engineering). This process requires taking not only the local stations and users into account, but also the protected users in the surrounding area.

An advantage here is that the devices that use the database do not need to perform any complex calculations or take any decisions. The effort is limited to entering the data in the database.

Hierarchical databases or a central database

An important issue is the appropriate database infrastructure.

A **central database** has the advantage that the CR device needs to know only one address for requesting data.

A disadvantage here is that with a large number of CR devices, the necessary data traffic to a central location and the necessary data rate on the central server represent very demanding requirements.

A prerequisite for a centrally maintained database (such on the European level) is the continual collection of data from a large surrounding area. Frequency allocations are national, which means it would be advantageous to have the data entered by the administrations or by suitably authorised bodies.

There is an inherent time lag between the current situation and database updating.

Although distributed databases could solve the requirements problem, the devices would have to be able to independently decide which database they need to access, which means that here again a policy element would be incorporated in the devices.

⁷ ERO Frequency Information System. The database of the European Radio Office for spectrum occupancy queries can be accessed at www.ero.dk/efis.

A possible alternative is a **hierarchical database system**, in which the initial query is sent to a central, trans-European database that in turn references the responsible local database.

However, in the short to medium term an international database does not appear to be advantageous because the database is closely linked to the operating mode of the devices, which means that a prerequisite for an international database is that the devices have a uniform operating mode. This is not possible with the current state of the technology.

Availability

Availability is an important property of databases. It requires round the clock support for databases. Redundant servers with continual updating are also necessary.

Safety and security aspects

Incorrect information in the database can cause problems for many users. Accordingly, communication between the users and the database should be protected, for example by means of suitable encryption.

Summary

A hierarchically structured positive database system appears to be the best option. The necessary entries might be made by the responsible local public authorities or by suitably authorised bodies.

Fast updating (around once per minute) is not without difficulties, since the entries are preceded by complex calculations.

Considerable costs can be expected to arise from these calculations, continual monitoring and adequate redundancy.

The cost of a database system increases substantially with increasing scope of performance, so it must be assumed that only a certain degree of currency can be achieved at a realistic cost. For this reason, database use should be combined with sensing so that short-term spectrum usage can also be taken into account.

In any case, it is necessary to define the various interfaces to the behaviour rules, the access cycles, and the formats.

3.2.2.3 Cognitive pilot channel (CPC)

As an alternative or in addition to sensing or geo-localisation with databases, a centralised infrastructure can manage and convey the cognitive information. A CPC provides information acquisition and resource management services by means of an infrastructure created for this purpose. Ideally, a CPC broadcasts the radio environment information constantly. This information can be received by every cognitive device.

Central databases may also be integrated into this concept. It is assumed that with a CPC it is possible to achieve very low latencies compared to a database system with an existing infrastructure used for communication between the CR devices and the database, so dynamic resource management at the scale of a frame period (milliseconds) is possible. Here the CPC is not only responsible for transmitting the available information, but is also considered to be an intelligent component that manages resources dynamically.

Compared to sensing, a CPC allows optimisation of spectrum occupancy and the resources.

In addition, a CPC can be used to cause CR devices to switch to a different frequency within a short time if necessary, which means that a CPC offers an advantage, compared to databases and geo-localisation, with regard to coexistence with protected services.

Pilot channel models

Private, public or hierarchical CPC

A **public CPC** is operated by a single operator and provides information about all available radio access technologies (RATs), resources and operators.

A **private CPC** broadcasts only information about the available RATs, frequencies and operators of interest to specific users. For example, a mobile service provider could operate a private CPC for the CR devices of its customers.

A **hierarchical CPC** is a hybrid solution and a special form of a public CPC. Part of the information broadcast by this CPC consists of access data for the private CPC needed by each CR device.

Which of these options – a public, private or hierarchical CPC – represents the best solution depends on the intended purpose of the CPC.

If the CPC is intended to optimise spectrum occupancy in general for many frequency bands (a ‘common cognitive pilot channel’), the best choice is a hierarchical CPC so that every frequency use is fundamentally based on the CPC. Harmonisation at the international or European level is advantageous in this case. This sort of model is being studied in the EU E2R project [E2R-CPC] and in ITU-R [ITU-R WP5A], for example. In this situation, the role of the public CPC is limited to referencing the private CPCs. The actual resource attribution bases on the information given by the private CPCs.

If on the other hand the sole objective is to control spectrum occupancy separately for individual frequency bands, harmonisation of the CPCs at the international level is not necessary. This task can be handled by a private CPC for each instance.

On-demand mode or broadcast mode

A CPC that only transmits in one direction and does not have a dedicated infrastructure for receiving a feedback channel is called a CPC operating in **broadcast mode**. In the simplest

case, it transmits only information indicating whether a frequency block is usable. Another option is to broadcast a list of available frequencies.

By contrast, a CPC can be designed so that it only responds to requests and receives feedback from the CR devices, with information on the spectrum usage of the devices, over a dedicated infrastructure. This version is called an **on-demand** CPC. It has the advantage that spectrum resources can be managed by the CPC in the same way as they are presently managed in LTE mobile telecommunication systems. Furthermore, other parameters can also be included, such as quality of service (QoS), interference level, required data rate, user priority, coding and transmit power, or results from a group of individual sensors can be evaluated (cooperative sensing).

A disadvantage is that the infrastructure must be very dense to enable reception of the feedback channel by the CPC infrastructure. (The link budget for the uplink is always the limiting factor due to the restricted transmit power.)

As setting up a feedback channel involves considerable effort and expense, a CPC operating in broadcast mode is the better choice if the sole objective is to protect other services.

Mesh approach versus coverage approach

In accordance with the ETSI technical report [ETSI+CPC], a distinction is made between the mesh approach and the coverage approach.

With the **mesh approach**, information on spectrum usage and availability is distributed over a relatively large area. The device must itself recognise which information is locally relevant for its usage. For this purpose, it uses geo-localisation to determine its location and extracts the corresponding data from the CPC. An advantage of the mesh approach is that a single CPC transmitter can cover a relatively large area, eliminating the need for dense or cellular structures. A disadvantage is that the necessary data rate increases with the size of the area to be covered.

By contrast, with the **coverage approach** the CPC information contains only the data needed locally in each instance. The device does not need to perform geo-localisation in order to extract the relevant data. Advantages of the coverage approach are that no geo-localisation is necessary and that the necessary data rate only needs to meet the need of a subregion. A disadvantage is that a dense infrastructure is necessary for sufficiently precise mapping of local spectrum occupancy.

Protection only or protection and attribution

Two types of CPC systems can be distinguished according to their primary purpose:

- **Protection CPC:** primarily intended to protect non-CR devices from CR devices in order to enable shared use of the same frequency band. For example, this could be a CPC for protecting safety-related applications.

- **Attribution CPC:** in addition to the function of a protection CPC, it is intended to enable optimal use of spectrum resources. This corresponds to the model of the E2R project [E2R-CPC] and the ETSI [ETSI_CPC].

An attribution CPC imposes substantially higher requirements on the infrastructure than a protection CPC, for two reasons:

- In contrast to a protection CPC, an attribution CPC requires a feedback channel. In rural areas, this presupposes suitably dense networks if the CPC must also serve mobile devices, due to the low transmit power of mobile CR devices.
- Large numbers of users must be taken into account in urban areas. For this reason, dense networks are also necessary here for an attribution CPC. The reason for this is that the volume of data that must be transmitted simultaneously to all users in order to map current spectrum usage is too large if the area to be served by a CPC base station is too large. This problem does not arise with protection-only CPCs.

Independent network or existing network

According to the definition provided here, a CPC always has a dedicated infrastructure that enables very short delays in the millisecond range. There are two options for the implementation of such a system:

- an independent network;
- a dedicated logical channel in an existing network.

Two aspects must be considered in order to determine which of these two options is preferable.

The first aspect is that according to the previously described properties of a CPC, a CPC system can be classified either as a mobile service or as a broadcasting service in the sense of the ITU. The second aspect is the distinction between attribution CPCs and protection CPCs. As described above, the infrastructure of an attribution CPC is substantially more complex than the infrastructure of a protection-only CPC. It can accordingly be assumed that attribution CPCs will preferably be established by parties having the financial and logistical resources necessary for this. In the ideal case, they will already have their own network, which they can employ as a resource and thus dispense with the construction of an independent CPC network.

The situation is different when it is only necessary to implement a protection CPC. An independent network is more suitable in this case than with an attribution CPC. The infrastructure is considerably less complex in this case. The entry threshold is therefore lower than with an attribution CPC, which means that even investors lacking dedicated networks could undertake this task.

Safety and security aspects

If the CPC is intended to enable coexistence with applications related to the safety service⁸ or applications especially sensitive to interference, the question of how manipulation of the CPC can be prevented is an issue.

There is also a risk that analysis of the CPC data could allow conclusions to be drawn regarding the operation of specific applications related to the safety service.

Cognitive pilot channel summary

- Implementation of a CPC that not only ensures the protection of non-CR devices but is also intended to enable the optimal use of spectrum resources (an attribution CPC) is most likely to occur within the context of existing infrastructures because dynamic resource management taking into account current usage requires a high degree of technical complexity.
- If by contrast the CPC is only intended to protect an application, localised establishment of a protection CPC is certainly possible.
- When CR devices are operated in combination with a CPC aiming for coexistence with applications related to the safety service, the risks of manipulation of the CPC and of analysis of the CPC data to obtain information on the operation of the applications must be considered.

3.2.2.4 Example derivation of technical constraints

A method for determining the detailed technical constraints for utilising CR is described in **Annex 4**; using vertical sharing in the 470–790 MHz band⁹ as an example.

3.2.3 Elements of planning and learning

Planning and learning are additional elements of a CR device.

These aspects require the detailed observation of spectrum usage. The information obtained in this way enables the CR device to model its frequency use behaviour so that it is compatible with the frequency use behaviour of other users. Accordingly, the CR device can plan its access to the spectrum in order to achieve the best possible efficiency.

However, advanced technologies of this sort are relatively immature at present.

It can be presumed that these technologies will be implemented only after the observation problem has been solved.

⁸ 'Any radiocommunication service used permanently or temporarily for the safeguarding of human life and property' Radio Regulations - Footnote 1.59.

⁹ This band is presently being studied as well, from a similar viewpoint and with regard to the concept of white space usage, by CEPT Working Group SE43 and several projects funded by the EU (such as CogEU).

3.2.4 Advantages of cognitive radio

3.2.4.1 Regarding the concept of spectral efficiency

Spectral efficiency is defined here as the ratio of the total data throughput of all users to the total available bandwidth.

CR is a technology that allows spectral efficiency to be increased. However, in each case it is necessary to consider the impact of the use of CR technology on other parameters that are also relevant to the use of this technology:

- Attribution of throughput to individual users;
- Coverage at a particular data rate;
- Impairment of non-CR uses (interference);
- Costs and economic benefits of CR technology.

3.2.4.2 Elements of increased spectral efficiency

Using CR increases spectral efficiency due to:

- more efficient spectrum occupancy and more efficient use of spectrum resources;
- reduced interference;
- selection of the optimal transmission method, taking other frequency users into account;
- spectrum resource usage adapted to existing usage schemes of non-CR applications.

These aspects are described below by first describing the existing restrictions on non-CR applications and then the potential improvements resulting from the use of CR. The improvements are illustrated by application examples.

3.2.4.3 Increasing spectrum occupancy efficiency by avoiding margins based on propagation statistics

Margins are assumed in spectrum resource management to compensate for statistical variations in propagation. This has two negative impacts on spectral efficiency:

- reduced spectral efficiency due to constraints on potential interference signals, which are not always actually necessary;
- provision of a margin for potential interference signals that is not always actually necessary in order to achieve the desired quality of service, with the result that the specified interference level is often higher than the necessary level, thus affecting spectral efficiency.

Spectral efficiency degradation occurs when precise, explicit information on actual propagation conditions and current spectrum usage is not available. This effect can be

reduced by using CR technology. It may even be possible to eliminate these restrictions entirely, depending on the capability of the utilised CR technology.

There are various types of margins, and the potential benefits of CR technology for each type are described below.

Margins for statistical wave propagation parameters

Wave propagation over relatively long distances is dependent on weather conditions and atmospheric (tropospheric) conditions; with the result that strong fading can occur. Due to diffraction effects, the magnitude of this effect increases with decreasing frequency. As this fading can vary within a relative short period (days), it is common practice to use 1% time curves for interference signals in order to ensure that they do not cause interference more than 1% of the time.

This is illustrated here by the 50% time and 1% time curves of ITU-R Recommendation ITU-R P.1546 [ITU-R P.1546] (see **Table 3.2**). They show the predicted field strength for specific time probabilities with a transmitter ERP of 1 kW at different effective antenna heights. **Table 3.2** shows extracts from the ITU-R recommendation for a transmitter with an effective antenna height of 150 m (clutter type: rural; terrestrial propagation).

	100 MHz		600 MHz		2000 MHz		Difference between 1% and 50%
	50%	1%	50%	1%	50%	1%	
10 km	78	80	78	80	80	80	0-2 dB
30 km	62	64	60	62	60	61	1-2 dB
50 km	50	53	45	51	45	50	2-6 dB
100 km	30	39	21	35	17	30	9-14 dB
200 km	8	25	-3	16	7	12	5-19 dB

Table 3.2: Selected field strength values (dB μ V/m) from ITU-R P.1546 for a transmitter with 1 kW ERP and an effective antenna height of 150 m (terrestrial propagation; clutter type: rural)

It can be seen that there is a difference of up to 19 dB between the 1% and 50% time curves. If (for example) a CR device intended to be used outside the service area of the transmitter of a primary service can determine the current magnitude of the interference from the transmitter at any given time, it may be able to use the frequency concerned most of the time. If there is no correlation between the propagation paths of the transmitting stations of the primary service, it may even be possible to use the frequency band continuously by changing to a different frequency with a low interference level whenever the interference level from a transmitter on the current frequency is high.

Margins for spatial decoupling (intervening walls and reflections)

CR devices also offer advantages for increasing spectral efficiency with regard to spatial decoupling. A statistical value is used for spatial decoupling with non-CR devices in order to avoid interference, with a fixed value and a standard deviation assumed for intervening walls. With a CR device, a value based on the actual situation can be used for intervening walls. Under suitable conditions, this allows higher occupancy to be achieved.

Margins for antenna decoupling: mutual directional characteristics of antennas

Fixed margins are also used for antenna decoupling in order to avoid potential interference. If high transmission reliability is required, the worst case is assumed (minimum decoupling resulting from the directional characteristics of the interference source and the victim of this interference).

If a CR device receives information on the directional characteristics of the devices potentially subject to interference, the actual antenna decoupling can be used as the basis for determining the optimal resource utilisation.

3.2.4.4 Avoiding spectrum resource blocking (reservation)

In the absence of CR technology, the spectrum requirements of radio applications are usually determined based on scenarios that ensure sufficient bandwidth for the majority of the scenarios.

However, these scenarios do not necessarily represent the average spectrum usage case, so it is certainly possible for spectrum resources in the band concerned to remain unused. These resources could be used temporarily for other purposes.

This possibility is already recognised in Germany in the form of short-term authorisation issued by the Federal Network Agency for Electricity, Gas, Telecommunications, Post and Railway on topics such as ENG/OB services based on tuning ranges. With the aid of CR, the frequency range actually available at a given time could be used automatically for the applications of other services.

3.2.4.5 Optimal algorithms for spectrum occupancy by self-configuration

A distinction is made between greenfield planning and iterative planning in conventional frequency planning. No existing use is assumed with greenfield planning, so a plan with any desired frequency uses can be developed, and an attempt is made to find an optimal usage scheme for the radio spectrum. If the frequency band is already used and other frequency uses are added, compulsory changes to existing uses of the radio spectrum are presently (without the use of CR) avoided as much as possible. The reasons for this are:

- The existing uses are not frequency agile (unable to optimise the transmit and/or receive unit for a particular frequency).
- The devices must be configured individually, and this requires human intervention.

- Generating a new occupancy plan and the corresponding rearrangements would require a large amount of time.
- An iterative planning process must be used if coordination is necessary.

The resulting plan is sub-optimal compared to the situation with greenfield planning in that the channels with the least interference are not necessarily the channels that are actually used. By contrast, with the use of CR devices the configuration process is automated, so automatic frequency planning according to the greenfield principle can be performed during ongoing operation and the optimal spectrum occupancy scheme could be realised.

Example applications

PMSE at major events

Relatively large events are planned in advance using human resources. If PMSE devices with CR functionality were used, the effort would be significantly less and the risk of potential interference would be reduced because the resulting plan would always be optimal and free of human errors.

ENG/OB service

There is rarely time for careful planning and configuration of the devices used in connection with unforeseeable major events. Automating the occupancy scheme would reduce the risk of interference.

3.2.4.6 Interference mitigation

Up to now, devices with low transmit power have used duty cycles with rigid time restrictions in order to mitigate mutual interference. The probability of interference can be reduced significantly by using pre-cognitive techniques such as dynamic frequency selection (DFS) or detect and avoid (DAA).

More exact knowledge of the radio environment backs the optimal usage of proven interference mitigation techniques.. A selection of these techniques is described in **Annex 5**.

3.2.4.7 Selection of the optimal transmission method, taking other frequency users into account

With the aid of information on whether and how existing systems occupy the frequency concerned, a CR device can adapt its use of more advanced and more efficient air interfaces to other users. If other non-compatible applications are not present, CR devices can use a modern air interface for transmission.

3.2.4.8 Adapting spectrum usage to existing usage schemes: spectral-temporal shaping

Adaptation to existing usage schemes allows overall spectral efficiency to be increased without restricting existing devices lacking CR capability. Spectrum mask adaptation is called ‘spectral shaping’ in Section 3.1.4.1. If the time structure is also taken into account, this technique can be called ‘spectral-temporal shaping’.

Example application

In the case of short range devices that operate with a limited duty cycle, their characteristic activity pattern can be utilised for other purposes. The spectrum resource can be used by a CR device during the pause intervals of the short range devices.

3.2.4.9 Lower entry barriers for launching new applications, and therefore lower prices for users

Current business models assume an exclusive spectrum with persistent access to this spectrum (with the exception of frequency bands for short range devices (SRDs)). For this reason, there is a lead time before spectrum use and a follow-up time after spectrum use.

With CR technology, more spectrum can be made available if devices can access more frequency bands or a lower probability of interference can be assured by an automated method.

In addition, with CR it would be possible to use self-configuring devices to achieve network coverage. In rural areas and inside buildings, self-configuring devices could improve network coverage and reduce the level of mutual interference.

3.2.5 Potential problems and other aspects to be considered with cognitive radio

The main problem with CR is the potential for hindrance to non-CR applications due to resource blocking or interference. As shown in **Section 3.2.2**, there are technical and economic limits on the individual methods, which do not always lead to adequate interference mitigating coexistence with CR devices.

Further restrictions result from coexisting non-CR devices, as described in **Annex 6**.

3.2.6 Services that use cognitive radio

In this section, we provide a brief overview of radio services in which applications are already able to use CR in the sense of the ITU-R definition or could do so in the future. See **Section 4, ‘Analysis of Specific Frequency Bands’**, for a more detailed description.

3.2.6.1 Amateur service

Horizontal sharing

CR is not used at present. Use in the context of horizontal sharing is conceivable in the future. Better dynamic resource sharing in the amateur service could be achieved by using cognitive technology.

Vertical sharing

Although coexistence with other CR users (vertical sharing with the amateur service as the primary service) is possible in principle, it is not possible to use a database or a CPC because this would require the registration of all users of the amateur service. Accordingly, vertical sharing (using only sensing) would only be possible if a certain probability of interference is considered acceptable.

In situations where the amateur service has a secondary status in coexistence with other services, the use of CR technology is possible in principle, but the cost/benefit ratio would be unreasonable. Users of the amateur service are usually technically skilled persons who pay attention to avoiding interference to other services. Consequently, it is probably not possible to achieve higher efficiency or better interference mitigation by means of sensing (not entirely reliable) or databases with CPC (high cost).

3.2.6.2 Mobile service

Horizontal sharing

Simple implementations of CR technology, such as WLAN or wireless microphones, already exist. They are used with both vertical sharing and horizontal sharing. They are designated 'pre-cognitive' because their functionality with regard to the elements of CR is substantially limited. Although simple elements of observation are present with these devices, the elements of orientation, planning and learning are absent. The elements of action are usually limited to either transmitting or not transmitting. Some examples are described in **Annex 6**. The use of cognitive technology will become increasingly widespread and increasingly complex with applications of this sort.

Although cognitive technology is not yet used in the bands utilised by the public mobile service (with the exception of 'conventional' resource attribution by a base station), initial use of cognitive technology to enable better resource attribution is foreseeable in the near future. An example of such use is self-configuring femtocells.

Cognitive technology is not presently used in the area of non-public mobile services (PMR and PAMR). Here again it can be expected that cognitive technology will make inroads in order to reduce the probability of interference.

Vertical sharing

As most systems already employ digital technology or will do so in the near future, they can tolerate a low statistical level of interference, which means that in principle it would be possible to introduce additional users based on cognitive technology because faulty data packets can be corrected or retransmitted.

3.2.6.3 Fixed service

The state of development of CR in the fixed service corresponds to that in the mobile service.

3.2.6.4 Broadcasting service

Horizontal sharing

Horizontal sharing is excluded due to the nature of the broadcasting service. A prerequisite for using cognitive technology is exact knowledge of the locations and types of passive receivers. This is not possible with the broadcasting service. In the opposite direction, the broadcasting service would need to obtain suitable knowledge of other services in order to adapt itself accordingly. This would require dynamic adaptation of the transmit and receive parameters. The antennas of broadcasting transmitters are usually optimised for a particular frequency band, so dynamic reconfiguration is limited as long as this technology is in use. In addition, broadcasting transmitters usually have high transmit power (10 to 100 kW), so dynamic modification of the transmit parameters would affect the interference environment over a range of several hundred kilometres.

Vertical sharing

Vertical sharing with services that use CR is possible. Applications are already being operated on a secondary basis without impairing the broadcasting service.

3.2.6.5 Fixed satellite service (FSS)

Horizontal sharing

Horizontal sharing is ruled out due to the nature of the fixed satellite service. A prerequisite for using cognitive technology is exact knowledge of the receivers (passive in this case as well). In the other direction, the fixed satellite service (i.e. the ground stations and the satellite) would need to adapt to local use by CR services having the same status. Although this sort of local subdivision is possible in the higher frequency bands because acceptable dimensions are possible with suitable antennas (for example, a service radius of 40 km can be achieved in the 22.1 GHz band), this sort of regional subdivision is not technically feasible in the 3.4–4.2 GHz band.

Vertical sharing

Resource sharing with services that use CR services is conceivable in principle. Coexistence with wideband applications on a non-interference basis already takes place in practice.

3.2.6.6 Mobile satellite service (MSS)

Horizontal sharing

No applications are presently known.

Vertical sharing

Vertical sharing with applications not related to the safety service is possible in principle.

In the case of applications related to the safety service, vertical sharing is not feasible in practice because it would require a database with information on the receive stations. Another potential objection is that a CPC would allow conclusions to be drawn about the operation of applications related to the safety service.

3.2.6.7 Aeronautical radionavigation service and aeronautical mobile service

Horizontal sharing

From the present perspective, horizontal sharing is apparently not feasible due to the required reliability.

Vertical sharing

Technical applications using CR technology in the bands concerned are conceivable in principle. For example, a CPC specifically for these bands could be broadcast. However, the same restrictions exist here as for applications related to the safety service in the mobile satellite service.

3.2.6.8 Radio astronomy service

Horizontal sharing

Horizontal sharing is impossible in principle due to the nature of the service, since the 'transmit facility' lacks CR capability.

Vertical sharing

As this (passive) use occurs in isolated locations and coexistence with other applications is conceivable with sufficient spatial decoupling and transmission restrictions, horizontal sharing based on geo-localisation using databases would be possible in principle. However, this is not advisable in light of the restrictions and the limited size of the usable frequency band.

3.2.6.9 Earth exploration satellite service

Horizontal sharing

Horizontal sharing is impossible to the nature of the service, since the 'transmit facility' lacks CR capability.

Vertical sharing

The same developments can be expected with the Earth exploration-satellite service as with the radio astronomy service.

4. Analysis of Specific Frequency Bands

4.1 Methodology description

Services that already use SDR and CR, or that could potentially use SDR and CR, are described in **Sections 3.1.6** and **3.2.6**. Here our objective is to discuss them in more detail with a selection of specific frequency bands.

The following questions are examined in each case:

- How can the radio environment be described?
- Are SDR and CR technologies already being used here, and what trend can be expected?
- Is horizontal and/or vertical sharing using CR technology possible and/or worthwhile?
- Are changes to the Radio Regulations or other regulatory changes necessary or advantageous?

In the treatment of the potential uses of CR technology, the discussion under the heading 'horizontal sharing' considers the scenario in which services or applications with the same status use the spectrum resources (which is the question of primary interest to this study) as well as the scenario with regard to the current or potential use of CR technology in an individual application. This form of combined analysis appears suitable because it can be foreseen, particularly considering the large variety of options available with the use of a CPC, that in the long term these two scenarios will become indistinguishable or will merge.

The frequency bands are classified according to their allocations so that general conclusions can be derived for the individual services.

The analysis is based on information from the following documents:

- (German) Frequency Allocation Ordinance [FreqBZPV]
- (German) Frequency Usage Plan [FreqNutz]
- (German) Administrative Regulations for the Non-public Land Mobile Service [VVnömL]
- (German) Administrative Regulations for Frequency Assignments in the Fixed Service [VVRichtfunk]
- Resolution of the President's Chamber of the Federal Agency for Electricity, Gas, Telecommunication, Post and Railways of 12 October 2009 on combining the Award of spectrum in the 790 to 862 MHz, 1710 to 1725 MHz and 1805 to 1820 MHz, with proceedings to award spectrum in the bands 1.8 GHz, 2 GHz and 2.6 GHz for wireless access for the provision of telecommunication services. [PRAESIDENTENKAMMER]
- Resolution of the President's Chamber of the Bundesnetzagentur (BNetzA/Federal Agency for Electricity, Gas, Telecommunication, Post and Railways) on proceedings for the award of frequencies in the 3400 to 3600 MHz frequency band for Broadband Wireless Access (BWA). [PRAESIDENTENKAMMER1]

- Frequency Allocation Procedure and Usage Conditions for Frequencies in the 3600 to 3800 MHz for the Implementation of Broadband Wireless Access (BWA) of 11 February 2009. [VERFUEGUNG1_09]

The analysis requires not only examining the frequency bands with regard to the possibility of resource sharing and adjacent channel compatibility within the frequency band, but also considering the question of compatibility with adjacent frequency bands. This leads to constraints on the CR and SDR devices with regard to their emissions outside the frequency band and with regard to their maximum allowable transmit power at the edges of the frequency band concerned.

In the analysis of CR in the various frequency bands, it was assumed that the constraints on CR are fashioned such that no additional restrictions on the frequency bands adjacent to the frequency bands concerned arise from the introduction of applications with cognitive technology:

- The constraints with regard to adjacent bands for horizontal sharing with CR should be identical to those for the existing assignments of the frequency band concerned.
- In the case of vertical sharing with CR, it is assumed that one of the constraints is that no additional restrictions arise for services in adjacent bands.
- In the case of SDR, it is assumed that the constraints regarding the adjacent bands are identical to those for the existing assignments of the frequency band concerned.

4.2 Frequency bands allocated to the mobile service

4.2.1 880–915 / 925–960 MHz

4.2.1.1 Radio environment

This frequency band is allocated to the fixed service and the mobile service (except the aeronautical mobile service) on a primary basis. At present, it is largely used for GSM and GSM-R, and in the near future, it is intended to be opened up to additional systems (UMTS).

GSM is planned according to a defined frequency reuse scheme because direct local reuse of frequencies would lead to interference. Two areas in which the same channel is used at the same time must be separated by at least the frequency reuse interval. The intermediate region in which the channel cannot be used for mobile service is regarded as 'white space'.¹⁰

In the near future, the 880–915 / 925–960 MHz band will also be used increasingly for UMTS-900 (a UMTS version adapted to the 900 MHz band). Technical constraints for this are already in place (see ECC Report 82 [ECC-Report82]). Due to the very high market

¹⁰ The unused channel frequency in the intermediate region is sometimes called 'white space'.

penetration of GSM-900, pan-European discontinuation of GSM-900 can be ruled out for the next ten years. In Germany as well, such a change cannot be expected in the short to medium term. However, the short life cycle of the terminal devices enables the rapid introduction of new technologies.

4.2.1.2 Current state of software defined radio and future trends

At present, GSM terminal devices are implemented exclusively with dedicated components. This same is true for existing base stations. However, base stations with SDR technology are increasingly being chosen as replacements for existing base stations in the renovation of the mobile telecommunication infrastructure. In the long term, it can be expected that most base stations will use SDR.

Flexible base stations for future-proof upgrading and conversion

As there are many different air interface technologies (known as ‘radio access technologies’ or RATs) and they are constantly being refined, it is advantageous to stop using discrete hardware components to implement the various air interfaces. Some currently available mobile telecommunication base stations allow software reconfiguration, such as changing from GSM to EDGE or from UMTS to HSPA. Systems that are fully software configurable are another step in the direction of SDR. They enable the flexible use of different mobile telecommunication standards in different frequency bands (e.g. Flexi Multiradio Base Station from Nokia Siemens and SingleRAN from Huawei). Revisions to the standards can be implemented by software (see e.g. [NSN_MULTIRADIO]).

SDR implementation at the terminal end

A switch to SDR can also be expected for terminals. The number of required components increases with the increasing number of RATs. Hardware implementation would restrict the form factor (miniaturisation) and lead to additional costs. The somewhat higher cost of SDR is offset by its distinctly higher flexibility, with the result that due to the large number of RAT options (GSM900, GSM1800, UMTS900, UMTS, and LTE with its derivatives) SDR can already be more advantageous than dedicated hardware solutions. Although implementation using dedicated components is still preferred, with the introduction of LTE more and more manufacturers will use SDR technology to implement the various air interfaces (see **Section 3.1, ‘Software defined radio’**).

Another advantage of SDR is that it allows the GSM-900 band to be combined with other bands (such as the 790–862 GHz band) for spectrum aggregation in order to obtain a broader virtual carrier (see **Section 3.1.4, ‘Spectrum aggregation’**).

4.2.1.3 Current state of cognitive radio and future trends

Horizontal sharing

Cognitive technology is not presently used in GSM-900. However, it is conceivable for cognitive technology to be used in order to obtain better data throughput in the network of a mobile telecommunication company or in several networks operated in parallel.

In combination with other technologies (beam forming and scheduling), detailed knowledge of the usage scenario (such as locations and user decoupling) can contribute to a significant increase in throughput.

Frequency resource utilisation can be improved by using a CPC. For this reason, ETSI Report TR 102 683 [ETSI_CPC] recommends a CPC within the GSM signal.

Changing between GSM, UMTS and LTE depending on availability

As mentioned above, the 880–915/925–960 MHz band is presently used for GSM and will soon be used for UMTS. GSM will certainly be maintained for a long time, but developments in the UMTS area (with the HSPA and HSPA+ versions) are ongoing. The implementation of LTE will start in 2010, and GSM will become less and less significant in the future. It can therefore be expected that devices supporting only UMTS or LTE will become predominant inside cells, with the result that the mobile service spectrum in these cells can only be used for these systems. The switchover could be managed with CR technology.

For this reason, it is conceivable that the introduction of new RATs will not require additional frequency bands in the future if CR is used. Transitions to increasingly more advanced technologies can occur continuously instead of being limited to discrete points in time.

Multihop relay

Intermediate stations (relay stations) with a better link budget to the base station than a direct link between the terminal and the base station can be used to reduce interference and increase capacity. In this process, data from several nodes is bundled and forwarded. This is method is called 'multihop'.

Each terminal also acts as a relay station for data from users. With suitable optimisation, the total power costs can be reduced and capacity can be increased (see e.g. [TUB_MULTIHOP]).

Alternatively, a stationary or fixed infrastructure can be used. This may be a base station (femtocell) logging in to an existing network.

To select the optimal hops, which mean selecting the number of hops and the users, it is necessary to have detailed knowledge at the millisecond level of the locations of the individual users, their mutual decoupling, and their maximum data transmission rates. This sort of knowledge is a cognitive behaviour, so multihop relay can be regarded as an element of CR.

Vertical sharing

Potential resources

GSM currently employs a quasi-periodic frequency reuse scheme, which results in regions in which specific frequencies are not used. These frequencies could potentially be used with lower transmit power levels.

With the change to UMTS, these 'white spaces' can no longer be defined as dedicated regions, since the same frequency is used in all radio cells with UMTS. In UMTS systems, different users are identified by different codes that must have a specific mathematical property called 'quasi-orthogonality'. In practice, the signals generated with these codes are not fully orthogonal, which leads to interference to other users. As a result, the total cell capacity is determined by the maximum allowable total interference level. The potentially usable free resources in this case are the unused quasi-orthogonal signals for other users, which can be used up to the point where the maximum total interference level is reached.

As a GSM-900 network has nearly complete geographic coverage, relatively large areas within which frequencies are very unused, cannot be expected.

CR offers major potential for utilising resources that are not used dynamically (in the available time slots). This situation varies rapidly, depending on the cell utilisation (required data rate and number of users).

Potential use by means of CR

The usages described above cannot be realised with full reliability using sensing (see **Section 3.2.2.1, 'Sensing'**).

Reliable identification of empty slots would be possible with geo-localisation and databases. However, due to the latencies that occur, geo-localisation with databases would not sufficient by itself be to allow the use of resources available due to incomplete cell utilisation. Particularly with UMTS usage, this would not be feasible because the available resources cannot be defined in the form of time frames and frequencies, but instead in the form of time-varying quasi-orthogonal codes and the available interference margin before the maximum total capacity is reached.

A CPC is necessary for full utilisation of the resources. However, operation of this CPC requires a constant supply of current information on the collective usage of the mobile service, so it appears that the most reasonable option is to have this CPC be operated directly by the operator of the mobile telecommunication network.

4.2.1.4 Advantages or necessity of regulatory changes

As previously mentioned, SDR technology is already being used. A gradual shift from GSM to UMTS (or LTE) will accelerate this process. The regulatory constraints necessary for a change to UMTS have already been defined, so no other changes are necessary. Future development of even more advanced air interfaces can also occur while complying with these constraints.

In the case of **CR with horizontal sharing**, it is already foreseeable that this can easily be integrated into existing resource management technologies. This does not lead to any changes to the interference conditions for services in adjoining frequency bands or coexisting services. Consequently, no changes to the regulations are necessary.

CR with vertical sharing would best be implemented using a CPC integrated into the mobile telecommunication network. Accordingly, this use would require close cooperation with the operator of the mobile telecommunication network. This does not lead to any changes to the regulations.

4.2.2 790–862 MHz

4.2.2.1 Radio environment

The 790–862 MHz frequency band is assigned jointly to the broadcasting service and the mobile service. Up to now channels 61 to 63 and 67 to 69 of this band have been used for military applications of the mobile service (tactical relay applications)¹¹. The broadcasting assignment is currently used in channels 64 to 66 for television broadcasting applications (DVB-T system).

The 2006 Regional Radio Conference (RRC-06) regarded the 790–862 MHz band as part of the broadcasting band, with the result that this band is designated for broadcasting in most (European) countries. At least in the short to medium term, further operation of high-power DVB-T transmitters must still be reckoned with in some European countries.

In addition, at the national level wireless microphones are allowed in channels 61 to 63 and 67 to 69 based on a limited-term general allocation.

The frequency band is assigned to the public mobile service and was auctioned 2010. From a regulatory perspective, the ‘duplex gap’ (821–832 MHz) continues to be available for wireless microphones by means of individual licenses.

The 790–862 MHz band is regarded as the initial frequency band for the introduction of UMTS Long Term Evolution (LTE) technology. Although other bands are also eligible, faster establishment of geographic coverage can be expected in the 790–862 MHz band due to the availability of existing GSM-900 sites.

¹¹ As this study only examines the question of whether regulatory changes are necessary at the international level, the question of whether a band is used for civil versus military purposes at the national level is irrelevant. It would only be significant in the context of a procedure for generating the frequency usage plan ordinance, which is not the subject of this study

4.2.2.2 Current state of software defined radio and future trends

As the 790–862 MHz band represents a new frequency band for mobile service, new base stations will be necessary, so it can be expected that SDR-based base stations will be used right from the start (see **Section 4.2.1.2**).

As the exact constraints for the mobile service spectrum mask may also vary from one country to the next (depending on whether channel 60 is used by the broadcasting service) and over time (due to replanning of broadcast transmitters), it appears sensible to equip the base stations accordingly.

If it is also desired to have DVB-T transmitters in operation, interference cancellation could be performed with SDR as described below.

Broadcasting services transmitters are usually operated with substantially higher transmit power than mobile service base stations. In this radio environment, a conventional base station of the sort used with UMTS/LTE would fail to receive mobile service signal because the sensitivity of the base station would be impaired by the high receive level of the DVB-T signal. With the aid of interference cancellation, operation is possible even with a dominant DVB-T interference signal. The DVB-T signal (here regarded as an interference signal) is reconstructed and subtracted from the total signal. Various algorithms for cancelling interference from DVB-T signals are described in [HONG_CHEN].

These interference cancellation algorithms can be retrofitted by software download.

Overall, a transition to SDR technology can be expected, just as in the other bands assigned to the public mobile service, in no small part due to the diversity of the UMTS/LTE standard.

4.2.2.3 Current state of cognitive radio and future trends

Horizontal sharing

The same trends as for the other frequency bands assigned to the public mobile service can be expected. However, the rapid introduction of cognitive technology could be simplified if SDR-based base stations are used right from the start.

Vertical sharing

The same aspects appear here as for the 880–915 / 925–960 MHz band.

4.2.2.4 Advantages or necessity of regulatory changes

For this band as well, and for the same reasons as for the 880–915 / 925–960 MHz band, there is no advantage from regulatory changes and no need for regulatory changes.

4.2.3 1920–1980 / 2110–2170 MHz

4.2.3.1 Radio environment

Pursuant to the (German) Frequency Allocation Ordinance, this band is allocated to the mobile service and the space exploration service (2110–2120 MHz). It is largely used by the public mobile service for UMTS. There are no restrictions on the mobile service for the protection of the space research service.

This frequency band is used primarily in conurbation areas.

4.2.3.2 Current state of software defined radio and future trends

The situation is currently the same as for the 880–915 / 925–960 MHz band.

The use of spectrum aggregation techniques for the frequency blocks auctioned in the first half of 2010 (1930–1940, 1950–1960, 2120–2130 and 2140–2150 MHz) is advantageous here as well because it can create carriers with bandwidths greater than 10 MHz.

4.2.3.3 Current state of cognitive radio and future trends

In general, the provision of mobile service can be improved with self-configuring base stations, if only to increase network density in conurbation centres or expand the network in rural regions.

Horizontal sharing

The situation is similar to that in the 880–915 / 925–960 MHz band. Unlike the latter band, UMTS is already being used here.

Vertical sharing

The situation is similar to that in the 880–915 / 925–960 MHz band.

From the limited degree of coverage outside urban areas, it can be concluded that spectrum resources that can potentially be used by CR are available there.

In addition, relatively faster decline in interference to the service using the CR system can be expected due to the relatively low transmit power of UMTS base stations.

4.2.3.4 Advantages or necessity of regulatory changes

For this band as well, and for the same reasons as for the 880–915 / 925–960 MHz band, there is no advantage from regulatory changes and no need for regulatory changes.

4.2.4 2500–2690 MHz

4.2.4.1 Radio environment

Pursuant to the (German) Frequency Allocation Ordinance, the entire 2500–2690 MHz band is allocated to the mobile service (with the exception of the aeronautical mobile service). The

2640–2655 MHz band is additionally assigned to the space research service (passive) and the Earth exploration-satellite service (passive) on a secondary basis. Passive sensors (radiometers) on board spacecraft are used for scientific and technical research, for the reception of radiation from the earth in order to study the properties of the earth, for research on natural phenomena, and for the acquisition of data on the state of the environment. According to the decision of the President's Chamber on the procedure for awarding spectrum in the 2500–2690 MHz band [PRAESIDENTENKAMMER], no protective measures are stipulated.

The 2655–2690 MHz band is additionally allocated to the radio astronomy service on a secondary basis for the reception of radio signals and radiation from outer space. The radio applications of the radio astronomy service are passive. The protection criteria for this passive radio application are stated in Recommendation ITU-R RA.769 [ITU-R RA.769]. According to footnote D149 to the German Allocation Table, all measures must be taken to protect the radio astronomy service against interference. According to the decision by the President's Chamber on the procedure for awarding spectrum in the 2500–2690 MHz band [PRAESIDENTENKAMMER], the sites in Effelsberg and Westerbork must be protected. Only the radio astronomy that uses the frequency band above 2690 MHz is taken into account.

It can be assumed that the band from 2500 to 2690 MHz will be used primarily in conurbation areas, since this HF band is less suitable for the economical provision of basic service in rural regions due to its physical propagation characteristics.

4.2.4.2 Current state of software defined radio and future trends

The same statements apply here as were previously made for the 790–862 MHz band.

4.2.4.3 Current state of cognitive radio and future trends

Horizontal sharing

Mutual synchronisation of TDD devices for the purpose of interference mitigation, as well as synchronisation of TDD devices with FDD devices for the same purpose, is possible with cognitive technology. This can be done by sensing or by using a CPC. A database would require continual updating in order to allow precise usage data to be transferred in real time. In the short to medium term, this sort of real-time transfer is only possible with a CPC.

Vertical sharing

The same conditions apply as for the 1920–1980 / 2110–2170 MHz band, and the same potential is available here.

4.2.4.4 Advantages or necessity of regulatory changes

For this band as well and for the same reasons as for the 880–915 / 925–960 MHz band, there is no advantage from regulatory changes and no need for regulatory changes.

4.3 Frequency bands allocated to the broadcasting service

4.3.1 470–790 MHz

4.3.1.1 Radio environment

The 470–790 MHz band is used by the broadcasting service, the radio astronomy service, and PMSE (programme making and special events) applications.

Broadcasting

In Europe, this band is predominantly used for analogue and digital terrestrial television based on the PAL or SECAM-standard (for analogue television) and the DVB-T standard (for digital television). The transition from analogue to digital television is in full swing in Europe, and in some countries (such as Germany) it is already completed. All countries of the EU are obliged to implement this transition by 2012.

PMSE (programme making and special events)

The 470–790 MHz band is additionally used by PMSE applications on a secondary basis. These applications can be classified as either electronic newsgathering outside broadcast (ENG/OB) or private mobile radio (PMR), which makes them applications of the mobile service or the fixed service.

These devices are needed for carrying out events, and they are used in large numbers with major events. This includes the transmission of voice, music and imagery as part of the production of news and events and technical support for these activities (in-ear monitors, wireless microphone systems (professional wireless microphone systems (PWMSs)) and wireless camera links, including ground-to-air links, telecommand/engineering links, remote control, point-to-point audio/video links, and talkback links).

In Germany, wireless microphones may be operated in channels 21–37 and 39–60. The operating frequencies are usually selected directly by the holder of the frequency assignment.

Radio astronomy

In addition, in some European countries channel 38 (in the 608–614 MHz band) is used for radio astronomy.

4.3.1.2 Current state of software defined radio and future trends

Broadcasting

SDR is already being used in broadcast receivers, although only for specific devices such as USB sticks. Many broadcast receivers are still implemented using discrete components, with a limited portion of the functionality being implemented in microcode. Receivers for digital

television and digital radio ('front ends') are always implemented in the form of a conventional RF section and a baseband chip. The baseband chip uses software to demodulate the most common digital television or digital radio signals (T-DAB, T-DMB, and VB-T/ISDB-T).

A trend toward SDR can be expected in the long term due to the availability of low-cost SDR components.

PMSE

SDR is not presently used for PMSE. In the near future, it is conceivable that private mobile radio will employ SDR technology (with the same platform as PPDR and BOS in the 459–470 MHz band).

Radio astronomy

No use of SDR for radio astronomy in channel 38 (608–614 MHz) is known.

4.3.1.3 Current state of cognitive radio and future trends

Horizontal sharing

Broadcasting

Due to the nature of the broadcasting service, there is no point in horizontal sharing. For one thing, broadcasting applications lack a feedback channel, so a broadcast receiver can make only a very limited contribution in a CR context, and for another, the large range of broadcast transmitters makes it impossible for them to detect the local radio links of other applications. In addition, the broadcasting service is a static application for which dynamic adjustment of transmission capacity makes no sense.

PMSE

PMSE applications have a secondary status in the frequency band concerned. With the use of CR technology, they could assume a horizontal sharing relationship with each other.

CR technology could contribute to the rapid optimisation of spectrum occupancy (see **Section 3.2.4**). As there is presently a shortage of spectrum resources for PMSE services and it is difficult to find usable spectrum, it would be advantageous to use existing resources more efficiently while respecting the demanding technical constraints for interference avoidance.

Vertical sharing

As described in Section 4.3.1.1, resources for vertical sharing are fundamentally available in the 470–790 MHz band.

Broadcasting

To ensure the protection of terrestrial television service, CR devices (also known as 'white space devices' (WSDs) in the 470–790 MHz band) must comply with specific technical and regulatory constraints. This means that the devices must first have the technical capability to identify the DVB-T service environment. Only after this is assured will it be possible to specify maximum allowable interference limits within a regulatory context.

In particular, the following items must be specified (see **Annex 6** for details):

- **Maximum transmit power of CR base stations with a permissible exclusion zone (a region free of any protected DVB-T receiving facility):** With an approved exclusion zone having a radius of 1 km, n+8 CR transmit power levels on the order of approximately 1 kW ERP (as commonly used in the mobile service) may be generated with a single channel. For CR base stations with a smaller exclusion zone and smaller frequency spacing, the allowable maximum transmit power is reduced accordingly; for example, it is in the order of 30 dBm with an exclusion zone having a radius of 100 m.
- **Maximum transmit power of portable CR devices:** In order to protect DVB-T devices for portable reception (stationary with a small portable antenna), CR devices must observe power restrictions lying approximately 10 dB below the typical values for a mobile service terminal. Significantly higher transmit power is possible with portable CR devices in a service area for DVB-T rooftop reception if suitable decoupling (polarisation, building penetration loss and diffraction loss) is assumed.

PMSE

It is conceivable that other applications with secondary status (in addition to PMSE) could use the frequency band, but with lower status than the PMSE applications. If these additional applications were equipped with CR technology, a vertical sharing situation would be present. Considerations similar to those for the broadcasting service would apply for the protection of the PMSE applications. However, as this scenario presumes the allocation to an additional service to the spectral band concerned and considerations of this sort are not the subject of this study, the implications of this scenario are not discussed in further detail here.

Radio astronomy

In light of the limited potentially usable spectrum, the effort and expense necessary for coexistence with a service or an application using CR technology are not worthwhile. Channel 38 (608–614 MHz) should be free of such applications.

4.3.1.4 Advantages or necessity of regulatory changes for cognitive radio

Regulatory changes at the ITU-R level are not necessary because the described CR technology can be operated entirely within the scope of the applicable regulations or is already being used in the form of pre-cognitive precursor systems.

The technical analysis shows that the most effective option for operating an application with CR technology would be vertical sharing based on geo-localisation with a database.

It would be advisable to adopt suitable technical recommendations, for example at the ECC level, in order to establish structures for the creation and maintenance of databases, for sensing, or for a pilot channel infrastructure.

4.4 Frequency bands allocated to the fixed-satellite service

4.4.1 3400–4200 MHz

4.4.1.1 Radio environment

According to the (German) Frequency Band Assignment Plan Ordinance, this band is assigned to the fixed satellite service, the fixed service, the amateur service, and the radiolocation service (at least in part).

The 3400–3600 MHz band is used by the fixed service for broadband wireless applications (broadband wireless access / BWA). This band is also used for a few ENG/OB applications. These uses are not allowed to interfere with other applications. The band is also earmarked for IMT by WRC-07, which means that usage by advanced cellular mobile telecommunication systems can be expected in the foreseeable future.

The 3400–3600 MHz band is also used by the fixed service for broadband wireless applications and by the fixed-satellite service for satellite service links. Interference to existing and coordinated receive facilities of the fixed-satellite service is not allowed. ECC Report 100 [ECC-Report100] forms the technical basis for the protection of these facilities. It derives mitigation distances, which specify the distances within which special measures are necessary for interference mitigation. These depend on the elevation and antenna size of the protected base station. The maximum mitigation distance mentioned in the report is 120 km. The 3800–4200 MHz band is jointly used for point-to-point links (fixed service) and service links (fixed-satellite service). Individual allocations are necessary for point-to-point links, so information on local usage is already available. In the case of the fixed-satellite service, no information on user receive sites is directly available.

A spectrum award procedure for frequencies in the 3400–3600 bands for broadband wireless access took place in 2008, in which the various frequencies were awarded to allocation regions. The award procedure included an obligation to establish a network. Most of the frequencies were awarded. Although the award procedure was implemented in a

fundamentally technology-neutral form, it can be assumed that the users will employ the WiMAX system.

4.4.1.2 Current state of software defined radio and future trends

Fixed service

WiMAX is one of the most widely distributed systems using SDR technology. Most WiMAX implementations are based on SDR. Among other reasons, this can be explained by the fact that most devices are operated in stationary mode, so power consumption is not a primary consideration as with other devices. Another reason is that a large number of algorithms in the standard are flexible, so they can be optimised individually and continually.

Mobile service

The same sort of evolution as with WiMAX can be expected in future standards for the mobile service, such as LTE Advanced.

Fixed-satellite service

SDR technology is not used at present. However, in the medium to long term it can be foreseen that SDR technology will gain a foothold in this area as well.

4.4.1.3 Current state of cognitive radio and future trends

Horizontal sharing

3400–3600 MHz

WiMAX products are already being equipped with cognitive technology for purposes such as linking base stations together into self-configuring networks.

3600–3800 MHz

Geo-localisation with a database could be used to protect the coordinated receive facilities of the satellite service. Using cognitive technology for the stationary operation of broadband wireless applications would be disproportionately costly. Simply using a database for setting up stationary WiMAX facilities would be sufficient.

3800–4200 MHz

No implementation of cognitive technology is foreseen for the fixed service or the fixed satellite service.

Vertical sharing

3400–3600 MHz

In the frequency bands used by the mobile service, the operation of additional applications using CR technology is possible in vertical sharing. Here the contours resulting from the award procedure can be used for the geo-localisation database.

As the data does not change over time, this form of geo-localisation with databases is the best choice, since sensing cannot be used due to the passive nature of satellite receive facilities and a CPC would be disproportionately expensive in view of the static nature of the data.

The individual assignments for ENG/OB would additionally need to be entered in the databases.

3600–3800 MHz

In addition to the contours of the award procedure for broadband wireless applications, the stations of the coordinated fixed-satellite service can be included in a database.

3800–4200 MHz

The introduction of CR technology for existing (or new) supplementary applications with vertical sharing relative to the primary service is fundamentally possible. As users can be localised either directly (fixed service) or indirectly (fixed-satellite service), a database can be generated from this information. The receive facilities could then be protected by geo-localisation. However, ECC Report 100 [ECC-Report100] indicates that in the worst case supplementary interference mitigation measures are still necessary at distances up to 100 km for low elevation angles (with a large azimuth to the west, such as over the USA, or to the east over Asia). The mitigation distance decreases rapidly at higher elevation angles (e.g. satellite close to 0° in a southerly direction). It is therefore mandatory to include the elevation and azimuth coordinates of the satellite receive facilities in the database.

As the mitigation distance can be more than 100 km, a national database that does not take foreign receive facilities into account is not sufficient.

4.4.1.4 Advantages or necessity of regulatory changes

For the 3400–4200 MHz band as well, no changes to the Radio Regulations are necessary or advantageous in connection with the introduction of SDR and CR technologies.

Using cognitive technology is not necessary for the erection of **stationary** facilities.

By contrast, a European database will be necessary for **portable** and handheld devices.

In the 3800–4200 MHz band, the introduction of additional applications that employ CR technology is possible with vertical sharing. Here future receive facilities must also be protected by entry in the database.

4.5 Other frequency bands

Other frequency bands are examined in tabular form below.

Frequency band	450-470 MHz
Radio environment	<p>This band is assigned to the mobile service on a primary basis. This assignment is used by the private mobile service (with 20 kHz channel width), private mobile / trunked radio (451.00-455.74 MHz and 461.00-465.74 MHz), wireless paging (with approximately 20 kHz channel width), and radio applications of the public railways (457.4-458.32 MHz and 467.4-468.32 MHz).</p> <p>The 449.75-450.25 MHz band is additionally assigned to the space operation service (earth to space direction) and the space research service (earth to space direction) on a secondary basis. These allocations are used for applications for orbit tracking and remote measurement and control of spacecraft, and for applications for radio traffic with spacecraft.</p> <p>Usage of the 454-456 MHz and 459-460 MHz bands by the mobile-satellite service and the land mobile service is limited to non-geostationary satellites.</p> <p>Finally, the following frequencies may also be used in mobile service for mobile communications onboard vessels: 457.5125 MHz, 457.550 MHz, 457.575 MHz, 467.525 MHz, 467.550 MHz, and 467.575 MHz. Devices with a channel spacing of 12.5 kHz may additionally use the following frequencies: 457.5375 MHz, 457.5625 MHz, 467.5375 MHz, and 467.5625 MHz.</p>
Current state of software defined radio and future trends	<p>Current analogue and digital mobile services operate in the 450-470 MHz band. The devices used for this purpose are manufactured in small series production volumes. SDR is presently not used in this connection.</p> <p>No utilisation of SDR is known for any other applications.</p> <p>The implementation of such SDR devices in the future is conceivable. This would result in a common technical platform for the private mobile service, and even the public safety radio (BOS), for operation in other frequency bands. The only differentiating factor would be the software.</p>

<p>Current state of cognitive radio and future trends</p>	<p>Horizontal sharing</p> <p>CR technology is not yet used in this band at present. As this primarily involves peer-to-peer networks, which means networks with direct links from one terminal to another terminal, it is possible to use CR technology to reduce the probability of interference. Precognitive techniques are already being used for shared frequencies (see [VVnömL]).</p> <p>In the long term, it is conceivable that the rigid allocation of individual frequencies to specific users could be managed in a more flexible manner. Subdivision into individual user groups could be eliminated, with a larger subband being used by a larger user group instead. However, the current methods for interference mitigation and resource assignment are relatively inflexible.</p> <p>Vertical sharing</p> <p>No information on the local positions of individual users is available, so sensing is the only option.</p>
<p>Advantages or necessity of regulatory changes</p>	<p>No changes to the Radio Regulations are necessary, since all potential uses can occur within the scope of the existing mobile service allocation.</p> <p>After a full transition to new systems with better interference mitigation techniques, abolition of the subdivision into narrow channels and user groups could be considered at the national level.</p>
<p>Frequency band</p>	<p>960–1215 MHz</p>
<p>Radio environment</p>	<p>This band is allocated to the aeronautical radionavigation service, the aeronautical mobile (R) service, and the aeronautical radionavigation-satellite service (space-earth and space-space directions)</p> <p>Use of the 960–1164 MHz band by the aeronautical radionavigation service is reserved worldwide for the operation and development of electronic aircraft navigation aids on board aircraft and the associated ground facilities.</p> <p>Use of the 960–1164 MHz band by the aeronautical mobile (R) service is restricted to systems operated in accordance with accepted international aviation standards.</p> <p>Radio stations of the aeronautical radionavigation satellite service</p>

	in the 1164-1215 MHz band do not enjoy any protection against interference from radio stations of the aeronautical radionavigation service in the 960-1215 MHz band.
Current state of software defined radio and future trends	No SDR applications in the aeronautical radionavigation service or the aeronautical mobile service are presently known for this frequency band. However, evolution to the use of SDR is probable.
Current state of cognitive radio and future trends	At present, CR technology is not yet used for the aeronautical radionavigation service or the aeronautical mobile service. The use of cognitive technology could be difficult due to military radio applications and the associated question of the extent to which the necessary information for cognitive devices could be made available.
Advantages or necessity of regulatory changes	CR is not used at present. No regulatory changes are necessary, since the use of cognitive technology could be implemented within the scope of the existing services with the present regulations.

Frequency band	1452-1492 MHz
Radio environment	<p>This band is allocated to the fixed service, the mobile service (except the aeronautical mobile (R) service), the broadcasting service and the broadcasting-satellite service on a primary basis.</p> <p>There are presently no applications in the fixed service.</p> <p>Use of this band for the mobile service (telemetry) will soon be discontinued.</p> <p>In the band 1452-1479.5 MHz, the broadcasting satellite service is not permitted to cause interference to the broadcasting service and cannot claim any protection against interference from the latter service.</p> <p>As part of ECC Report 121 [ECC-Report121], coexistence between wireless microphones and broadcasting was studied and the use of precognitive techniques (detect and avoid, DAA) was proposed.</p> <p>The 1452-1479.5 MHz band is presently not used by the broadcasting service in Germany.</p>
Current state of software defined radio and future trends	<p>No utilisation of SDR technology for professional wireless microphone systems (PWMS) is expected in the foreseeable future.</p> <p>Receivers for the 1479.5-1492 MHz band have already been</p>

	<p>implemented using SDR. Among other things, this enables a seamless transition between terrestrial and satellite signals because both types of signals can be received and processed with the same receive unit due to the adjacency of the frequencies.</p>
<p>Current state of cognitive radio and future trends</p>	<p>Horizontal sharing</p> <p>It is foreseeable that wireless microphones will be equipped with ‘detect and avoid’ capability (a precognitive technique).</p> <p>Neither the broadcasting satellite service nor the broadcasting service will use cognitive techniques.</p> <p>Vertical sharing</p> <p>As the 1452–1479.5 MHz band is presently used only by wireless microphones for ‘non-professional production’¹² purposes, the introduction of additional applications by means of cognitive technology is conceivable. Adequate interference mitigation could be achieved by means of sensing. This does not require any additional infrastructure and is thus the most economical option.</p> <p>However, future usage of the band is uncertain and the situations in the various European countries are different, so it should be ensured that the devices concerned are able to adapt to the actual circumstances. Geo-localisation with a database could serve as a cognition tool.</p>
<p>Advantages or necessity of regulatory changes</p>	<p>Regulatory changes are neither necessary nor advantageous for the introduction of CR and SDR technology.</p>

¹² The German administrative regulations for the allocation of spectrum resources to the non-public terrestrial mobile service (VVnömL) stipulate that **professional** wireless productions require a higher level of protection than **non-professional** wireless applications. According to this stipulation, professional wireless production is the ‘commercially and professionally executed use of wireless production resources’, such as programme production, theatre performances, and concerts by professional music groups

Frequency band	1710-1785 / 1805-1880 MHz
Radio environment	<p>The 1710-1780.6 / 1805-1875.5 MHz band is presently available to the public mobile service.</p> <p>There is presently no usage in the 1780-1782 MHz and 1875.6-1880 MHz bands.</p> <p>There are military applications (fixed service) in the 1782-1785 MHz band.</p> <p>The 1718.8-1722.2 MHz band is additionally allocated to the radio astronomy service on a secondary basis. No protective measures for this are provided in the decision of the President's Chamber on the procedure for awarding spectrum in the 1710-1725 MHz band.</p> <p>Frequency usage by the mobile service is highly diverse:</p> <ul style="list-style-type: none"> - Part of the spectrum is used by two mobile telecommunication network operators for GSM. The usage scheme is similar to the scheme for GSM-900. The frequencies are not used in conurbation areas, but instead used to achieve a second (if incomplete) area coverage. - Another part of the spectrum is used by two other mobile telecommunication network operators. As these frequencies were first used only after a full-coverage network had already been established in the 880-960 Hz band, the frequencies in the 1710-1780.6 MHz and 1805-1875.6 MHz bands are only used in locations where this is necessary for capacity reasons. If only frequencies in the 2.6 GHz band are available to these operators for UMTS LTE, the frequencies in the 1710-1780.6 MHz and 1805-1875.6 MHz bands could be used for UMTS-LTE in locations where they are not already used for GSM. <p>The newly available frequencies will presumably be used for UMTS UTRA FDD or UMTS LTE. Whether they will be used everywhere or only locally (e.g. only in conurbation areas) depends on whether the network operators in question use frequencies below 1 GHz for the systems concerned (UMTS WCDMA or LTE).</p>

<p>Current state of software defined radio and future trends</p>	<p>Developments here are similar to those in the other mobile service bands:</p> <p>If the frequency block is used for GSM, development will be similar to that for the 880–915 / 925–960 MHz band.</p> <p>If the frequency block is used for UMTS WCDMA, development will be similar to that for the 1920–1980 / 2110–2170 MHz band.</p> <p>If the frequency block is used for UMTS LTE, development will be similar to that for the 790–862 MHz band.</p>
<p>Current state of cognitive radio and future trends</p>	<p>Horizontal sharing</p> <p>The development of CR depends on the technology that is used. Its course will be similar to the course of development in the other mobile service bands using corresponding technologies (see Section 4.2).</p> <p>Developments will be similar to those in the other mobile service frequency bands using corresponding technologies.</p> <p>Vertical sharing</p> <p>Developments will be similar to those in the other mobile service frequency bands using corresponding technologies.</p> <p>The scope of resources potentially available to additional users based on cognitive technology with vertical sharing varies, depending on whether the frequencies are used to expand an existing network or to establish a new network.</p> <p>Compatibility with military applications in the adjacent frequency band must be ensured for the 1780.6–1782 MHz band.</p> <p>It would be necessary to reckon with significant restrictions for the 1875.6–1880 MHz band in order to ensure compatibility with potential nearby mobile service terminals (near–far problem), so in technical terms only vertical sharing would be feasible in locations where the mobile telecommunication network operator that utilises the 1870.6–1875.6 MHz band does not use these frequencies.</p>
<p>Advantages or necessity of regulatory changes</p>	<p>The same observations as for the other frequency bands used by the public mobile service apply here.</p>

Frequency band	1980-2010 MHz
Radio environment	This band is allocated to the mobile satellite service (earth-space direction) and is intended to be used for the transmission of data and multimedia services. The frequency band has been awarded over all of Europe. According to the German Frequency Usage Plan, ground-based components may also be used to improve the provision of radio supply.
Current state of software defined radio and future trends	An evolution similar to the evolution of the broadcasting-satellite service in the 1479.5-1492 MHz band can be expected here.
Current state of cognitive radio and future trends	<p>Horizontal sharing</p> <p>As the anticipated applications will probably relate to broadcasting systems, developments similar to those in the 470-790 MHz broadcasting band can be expected.</p> <p>Vertical sharing</p> <p>The frequency usage scheme of the anticipated applications is largely unknown, so it is not possible to draw any conclusions regarding the options and potential resources for additional users with the aid of cognitive technology based on vertical sharing.</p>
Advantages or necessity of regulatory changes	At present, regulatory changes are neither necessary nor advantageous.

Frequency band	2025-2110 MHz
Radio environment	This band is allocated to the fixed service, the space research service, the Earth exploration-satellite service, and the space operations service. Military applications are operated in the fixed service.
Current state of software defined radio and future trends	<p>No usage information is available for the military applications in the fixed service.</p> <p>SDR technology is suitable for the space research service, the earth exploration-satellite service, and the space operations service, and it is already used in some applications to improve signal processing capability (e.g. interference signal cancellation).</p>
Current state of cognitive radio and	No information on CR usage is available for the military applications in the fixed service and applications in the space

future trends	research service, the Earth exploration-satellite service or the space operations service.
Advantages or necessity of regulatory changes	The introduction of cognitive users with vertical sharing is not possible as long as no usage information is available. No regulatory changes are necessary or advantageous.

Frequency band	2200–2290 MHz
Radio environment	This band is assigned to the Earth exploration-satellite service, the space research service, the space operations service, the fixed service and the mobile service on a primary basis. Usage by military applications is present in the fixed service. No information is available on usage in the mobile service.
Current state of software defined radio and future trends	SDR is suitable for the space research service, the Earth exploration-satellite service, and the space operations service, and it is already used in some applications to improve signal processing capability (e.g. interference signal cancellation).
Current state of cognitive radio and future trends	CR technology cannot be introduced as long as there are usages for which no information is available.
Advantages or necessity of regulatory changes	The introduction of cognitive technology with horizontal or vertical sharing is not possible as long as no information on existing applications is available. Consequently, regulatory changes are neither necessary nor advantageous.

Frequency band	2320–2400 MHz
Radio environment	This band is assigned to the mobile service on a primary basis. It is additionally assigned to the radiolocation service and the amateur radio service on a secondary basis. The entire band is used by non-navigational radiolocation service applications. The 2333–2350 MHz band is used for wireless cameras, while the 2320–2350 MHz band is used for ENG/OB. This requires individual assignments, which are granted only with the agreement of the military. The 2350–2400 MHz band is used for military radio applications

	within the scope of the mobile service allocation.
Current state of software defined radio and future trends	<p>No usage information is available on military applications.</p> <p>SDR is currently not used for wireless cameras or ENG/OB applications. A transition to SDR technology is conceivable. This would enable significantly more flexible and efficient spectrum usage in this band.</p> <p>SDR technology is already used in the amateur service.</p>
Current state of cognitive radio and future trends	<p>Horizontal sharing</p> <p>No usage information is available on military applications.</p> <p>With ENG/OB and wireless camera applications, the use of cognitive technology could enable a lower probability of interference and higher efficiency. This would not alter the individual assignment procedure, since it involves a purely technical measure.</p> <p>Vertical sharing</p> <p>As the entire band is used by military applications (including the radiolocation service), whose usage scheme is unknown for security reasons, the introduction of CR technology is currently not possible.</p>
Advantages or necessity of regulatory changes	No regulatory changes are necessary or advantageous.

Frequency band	2400–2483.5 MHz
Radio environment	<p>This band is allocated to the mobile service on a primary basis. It is additionally allocated to the amateur service (2400–2450 MHz band), the amateur satellite service, and the radiolocation service on a secondary basis.</p> <p>Usage by military applications and ENG/OB applications is present in the mobile service.</p> <p>Usage for short-range military applications is present in the radiolocation service.</p> <p>The entire band is also available to industrial, scientific, and medical (ISM) applications. Radio services that use this band must accept any interference that may be caused by these applications.</p>

	<p>Furthermore, this band is also used by the following applications:</p> <ul style="list-style-type: none"> - private mobile radio; - physics demonstrations in educational institutions; - short-range devices (SRDs); - WLAN and - public railway radio applications.
<p>Current state of software defined radio and future trends</p>	<p>No usage information is available on military applications.</p> <p>SDR is currently not used for wireless cameras or ENG/OB applications. The use of SDR technology would lead to more flexible spectrum usage. This also applies to the private mobile service and the radio applications of the public railways.</p> <p>WLAN applications are currently implemented with dedicated components. A transition to an SDR solution that integrates multiple air interfaces is conceivable in the medium to long term.</p> <p>SDR implementations have been used only rarely for short range devices up to now. The transition to SDR depends essentially on the ratio of the costs arising from the increased complexity to the additional benefits.</p>
<p>Current state of cognitive radio and future trends</p>	<p>Horizontal sharing</p> <p>Precognitive techniques are already being used for interference mitigation. In the future, cognitive or precognitive techniques will make inroads in short range devices.</p> <p>No usage information is available on military applications.</p> <p>The introduction of cognitive technology for interference mitigation is foreseeable for other applications (private mobile service and ENG/OB).</p> <p>Vertical sharing</p> <p>The band is used mainly by devices for which interference mitigation is achieved by means of (mandatory) transmit power limitation and selection of a suitable channel by the user.</p> <p>Protection of military applications by means of cognitive technology is not possible because no information on military usage is available.</p>
<p>Advantages or necessity of regulatory changes</p>	<p>For radio applications such as the private mobile service and ENG/OB or short range devices, the introduction of cognitive technology would be advantageous for interference mitigation.</p>

	<p>However, the level of complexity of the cognitive technology should have a reasonable relationship to the degree of complexity of the other functions of the devices concerned.</p> <p>As these are relatively low-power devices, it would not be necessary to use a database; sensing would be adequate.</p> <p>Regulatory changes are not necessary for the use of CR technology in this band, and no advantages would arise from regulatory changes.</p>
--	--

Frequency band	2700–2900 MHz
Radio environment	<p>This band is allocated to the aeronautical radionavigation service and the radiolocation service.</p> <p>The allocation to the aeronautical radionavigation service is used for aircraft radar systems at airports.</p> <p>The allocation to the radiolocation service is used for military applications.</p> <p>Additionally, wireless cameras can be used in this band by means of individual assignments. These individual assignments must be coordinated with the military and with the users of aeronautical radionavigation service applications and the wireless cameras are not allowed to interfere with these applications.</p>
Current state of software defined radio and future trends	<p>No usage information is available on military applications.</p> <p>Some radar systems have already been implemented using SDR. No information is available on the air traffic control (ATC) radar systems.</p>
Current state of cognitive radio and future trends	<p>No usage information is available on military applications.</p> <p>The use of cognitive technology is not relevant for radar systems.</p> <p>Allowing vertical sharing of the frequency band by existing (or new) applications with CR technology is not possible because it would not be possible to provide adequate protection for the safety-related applications. Sensing only does not provide sufficient protection.</p> <p>Exact localisation of the military applications is a prerequisite for the introduction of databases. This would pose a security risk. Usage of a CPC would allow conclusions to be drawn regarding the</p>

	temporal and local use of applications related to the safety service. In addition, the CPC data could be altered abusively in order to intentionally interfere with applications related to the safety service.
Advantages or necessity of regulatory changes	Regulatory changes are not necessary because there is no intention of introducing CR with vertical sharing. No regulatory changes are necessary for the potential implementation of radar systems or military applications with the aid of CR.

Frequency band	4200–4400 MHz
Radio environment	This frequency band is allocated to the aeronautical radionavigation service on a primary basis. Its use by the aeronautical radionavigation service is exclusively reserved for radio altimeters on board aircraft and associated automatic response devices on the ground. This band is additionally allocated to the Earth exploration-satellite service and the space research service for use with passive sensors on a secondary basis.
Current state of software defined radio and future trends	Some radar systems have already been implemented using SDR. No information is available on the air traffic control (ATC) radar systems. SDR technology can be or is already being used in some applications for the space research service, the earth exploration service and the space operations service in order to improve signal processing capability (e.g. interference signal cancellation).
Current state of cognitive radio and future trends	The same considerations as for the 2700–2900 MHz band apply here.
Advantages or necessity of regulatory changes	Regulatory changes are not necessary and would not be advantageous. The introduction of CR technology in this band is not feasible due to the military applications.

5. Analysis of the Pros and Cons of Potential Regulatory Changes

5.1 Technical conclusions from the analysis of specific frequency bands

5.1.1 Mobile service

5.1.1.1 Software defined radio

SDR will be used in connection with the introduction of new systems in the non-public mobile sector (PMR/PAMR). Existing systems employ pure hardware solutions. The renovation cycle is significantly longer than in the public mobile sector.

SDR has scarcely been used up to now in the public mobile service. However, base stations with SDR technology are increasingly being chosen as replacements for existing base stations in the renovation of the mobile service infrastructure. In the long term, it can be expected that most base stations will use SDR. A change to SDR can also be expected for terminals.

5.1.1.2 Cognitive radio

Horizontal sharing

The frequency band analysis shows that CR technology is already being used and that horizontal sharing is already taking place in mobile services, for example with precognitive systems.

Vertical sharing

As most systems in the examined frequency bands already employ digital technology or will do so in the near future, the introduction of cognitive methods with existing (or new) applications is possible in principle. If only sensing is used, the interference level will rise significantly if there is intensive additional use of the spectrum. Simple spectrum sensing is adequate if only users with low output power are allowed and a certain level of interference is acceptable.

If instead interference mitigation is the primary objective, geo-localisation with databases could achieve a significantly better interference situation but would allow full utilisation of only a fraction of the resources made available by the dynamic usage of a mobile service. It is an open question whether the benefits of the spectrum that could be made available in this manner would justify the cost of establishing a database.

The goals of interference mitigation and maximum resource exploitation could best be achieved in such cases by using a CPC to allocate the resources. However, this would involve considerable costs if the CPC were structured independently and required independently acquire information on the radio environment. As the spectrum usage information is already

available in the mobile telecommunication infrastructure, it would appear more appropriate to operate the CPC as an integrated component of the mobile service infrastructure.

5.1.2 Broadcasting service

5.1.2.1 Software defined radio

SDR is already being used in receivers for the broadcasting service, although only in specific devices such as USB sticks.

A trend toward SDR can nevertheless be expected in the long term due to the availability of low-cost SDR components.

5.1.2.2 Cognitive radio

Horizontal sharing

Horizontal sharing with other users based on CR technology is not possible for the broadcasting service due to the nature of the service. Broadcasting applications lack a feedback channel, and due to their large range, it is not possible for them to detect the radio links of other applications.

Vertical sharing

Vertical sharing with other services that use CR is possible in principle. However, it would require a certain amount of effort and expense (geo-localisation with databases, sensing and power restrictions) to limit interference to an acceptable level.

5.1.3 Fixed-satellite service

5.1.3.1 Software defined radio

SDR technologies are not used at present. However, in the medium to long term it can be foreseen that SDR technology will gain a foothold in this area as well.

5.1.3.2 Cognitive radio

Horizontal sharing

Horizontal sharing is ruled out due to the nature of the fixed satellite service. It is practically impossible for a satellite to detect the radio links of other users.

Vertical sharing

Resource sharing with other applications that use CR technology is conceivable, since the probability of interference can be reduced by using a database and specifying suitable constraints, among other options. The subband examined in the analysis (3400–3800 MHz) has already been released for broadband wireless access (BWA) with technical constraints to

protect the fixed satellite service. This protection could be automated by using cognitive technology under the conditions described above.

5.1.4 Radio astronomy service and other passive services

5.1.4.1 Software defined radio

Receive facilities for radio astronomy are already being operated with SDR to allow signal processing to be used to improve the suppression of adjacent-band interference.

5.1.4.2 Cognitive radio

Horizontal sharing

Horizontal sharing is excluded due to the nature of the services. No influence can be exerted on the 'transmit facilities'.

Vertical sharing

As this (passive) usage occurs in isolated locations and coexistence with other applications is conceivable with sufficient spatial decoupling and transmission restrictions, in principle vertical sharing based on geo-localisation using databases would be possible in this case. Nevertheless, opening up this allocation is not advisable in light of the restrictions and the limited size of the available frequency band.

5.1.5 Aeronautical radionavigation service

5.1.5.1 Software defined radio

For the most part, SDR is not yet used in the aeronautical radionavigation service, but implementations are conceivable in the future. For safety reasons, reconfiguration is difficult to imagine. No information on the subject of SDR was available for the 960–1215 MHz band examined in the analysis.

5.1.5.2 Cognitive radio

Horizontal sharing

CR is not yet used in the aeronautical radionavigation services, although it can already be foreseen that this technology will be used in the future. However, horizontal sharing with other services should be excluded due to the potential safety risks.

Vertical sharing

Although vertical sharing by other applications using CR technology in the bands concerned is in principle possible from a technical perspective, the potential safety risks may argue against it. A CPC could be broadcast specifically for these bands, but the benefits would be

low relative to the cost. In addition, the CPC would need to be protected against manipulation by unauthorised parties.

5.2 Changes to the Radio Regulations for software defined radio

The frequency band analysis shows that SDR technology is already being used for nearly all radio services and will be used more and more in the future. The transition times differ from one service to the next. As all of these uses exclusively involve the implementation of technology in existing systems, there is no need for changes to the Radio Regulations.

For the same reason, there is no need for changes to other regulations at any level, neither international nor national.

5.3 Changes to the Radio Regulations for cognitive radio

The introduction of CR technology for radio applications, regardless of whether the applications share the spectrum vertically or horizontally, does not justify changes to the Radio Regulations. As the applications concerned do not claim protection with respect to other services and are not allowed to generate any interference, they can be introduced based on Article 4.4 of the Radio Regulations¹³ without any need for frequency allocations. Nevertheless, the formulation or amendment of ITU-R recommendations, such as recommendations on the configuration of technical parameters, could foster the emergence of the broadest possible worldwide market. Binding trans-European regulation of these technical parameters requires stipulations issued by the ECC. As the frequency assignment data and the applications to be protected are country-specific, administration of the entries in the geodatabases should take place at the national level.

5.4 Changes to the Radio Regulations for cognitive pilot channels

A specific question in connection with agenda item 1.19 of WRC-12 is whether cognitive pilot channels need to be dealt with separately in the Radio Regulations. The analysis of specific frequency bands shows that CR does not necessarily need to be operated by means of a CPC. An independent CPC would be costly. If it were to be implemented, a more reasonable approach would be to build it on top of an existing infrastructure and use the spectrum available to this infrastructure.

For technical and economic reasons, mandatory worldwide harmonisation of the parameters of such a CPC appears to be neither necessary nor realistic under current conditions, and at best it can be regarded as premature.

¹³ 'Administrations of the Member States shall not assign to a station any frequency in derogation of either the Table of Frequency Allocations in this Chapter or the other provisions of these Regulations, except on the express condition that such a station, when using such a frequency assignment, shall not cause harmful interference to, and shall not claim protection from harmful interference caused by a station operating in accordance with the provisions of the Constitution, the Convention and these Regulations.'

5.5 Optional regulatory changes to foster cognitive radio

In contrast to the fundamental absence of any need for changes to the Radio Regulations, recommendations for specific frequency bands could be developed or amended at the ITU level, and modifications to regulations at subordinate levels, such as the European or national level, could be undertaken as supportive measures and fostering CR.

The formulation or amendment of ITU-R recommendations, such as recommendations on the configuration of technical parameters, could foster the emergence of the broadest possible worldwide market.

Binding trans-European regulation of these technical parameters requires stipulations issued by the ECC.

For the introduction of CR technology with vertical sharing in the 470–790 MHz band or in the public mobile service bands, potential regulatory measures could involve amending ECC Recommendation 70-03¹⁴. The amendment should include a reference to a standard and formulating a suitable ECC decision specifying, for example, the behaviour of the CR devices, the database update cycle, the frequency distances to the primary user and the maximum permissible transmit power.

In parallel with this, a corresponding standard for the implementation of CR devices could be developed by ETSI.

Furthermore, the constraints for establishing and updating a database must be clarified. As the parameters of the applications to be protected are country-specific, administration of the entries in the geodatabases and harmonisation of the results for both horizontal and vertical sharing should take place at the national level.

Abolition of the subdivision into narrowband channels and user groups in the 450–470 MHz band should be considered at the national level.

¹⁴ CEPT Recommendation for Short Range Devices

6. Conclusions

The objective of this study is to answer the questions listed below.

Are there any limitations on the spectrum that can be used by SDR or CR due to physical restrictions?

In the analysis of the frequency-dependent aspects of SDR, it was found that there are presently limits on the technical feasibility of SDR implementations:

Large bandwidths and high signal flexibility lead to high power consumption by the device. A bandwidth of 500 MHz is presently realistic for portable devices. The restrictions arise from the limitations of antennas, amplifiers, filters and A/D or D/A converters.

Reasonably priced SDR devices are only available for specific frequency bands with a bandwidth of several hundred megahertz or for a specific group of frequency bands with an equivalent total bandwidth. Larger bandwidths can be expected in the future as a result of technological progress.

As CR devices achieve their highest flexibility by means of SDR, these restrictions apply to CR devices as well.

Need for changes to the Radio Regulations with regard to software defined radio

The study shows that SDR only involves the implementation of existing applications, for which reason SDR is independent of specific services and frequencies in terms of frequency regulation. Accordingly, the use of SDR technology does not give rise to any need for changes to the Radio Regulations.

Need for changes to the Radio Regulations with regard to cognitive radio

The use of CR technology also does not give rise to any need for changes to the Radio Regulations. Insofar as the services or applications that use CR are not able to claim protection with respect to other services, they are not allowed to generate any interference and they can be introduced based on Article 4.4 of the Radio Regulations¹⁵ without any need for new frequency assignments. Accordingly, changes to the regulations are neither necessary nor advantageous.

Insofar as services with CR are introduced based on horizontal sharing, usage with the existing allocations occurs under the same conditions (protection and interference), so here again, there is no need for changes to the regulations.

¹⁵ 'Administrations of the Member States shall not assign to a station any frequency in derogation of either the Table of Frequency Allocations in this Chapter or the other provisions of these Regulations, except on the express condition that such a station, when using such a frequency assignment, shall not cause harmful interference to, and shall not claim protection from harmful interference caused by a station operating in accordance with the provisions of the Constitution, the Convention and these Regulations.'

From the analysis of specific frequency bands, it can be seen that differentiation of individual cases by frequency band is necessary in order to discuss the specific options and constraints for the introduction of CR devices. Only the general question of whether the use of CR can be considered in principle can be answered for individual services without reference to specific frequency bands.

Blanket restrictions to which CR systems and devices should or must comply

With regard to the introduction of CR devices, it can be said in general that sensing alone does not lead to adequate interference mitigation, so this technique by itself can only be used with low-power devices for which the greatest possible interference mitigation is not necessary.

Geo-localisation with databases is necessary for other applications that use CR technology with vertical sharing.

By contrast, a CPC would be necessary in order to take very short-term variations in frequency usage into account, such as those with duration in the order of a typical mobile telecommunication time frame in the millisecond range, and to protect applications related to the safety service. A CPC with full geographic coverage is more costly than generating and maintaining a database.

In frequency bands in which applications related to the safety service are operated, it is technically possible to use applications employing CR technology. A CPC specifically for these bands could be broadcast, but the benefits would be relatively low relative to the cost. In addition, the CPC would need to be protected against manipulation by unauthorised parties.

As (passive) spectrum usage by radio astronomy (for example) only occurs in isolated locations, coexistence with other applications on the basis of geo-localisation with databases would be conceivable with sufficient spatial decoupling and transmission restrictions. However, operating other, CR-based applications is not advisable in light of the technical restrictions and, in particular, the limited size of the usable frequency band.

Recommendations

In summary, the following recommendations may be made:

1. The Radio Regulations in their current form provide sufficient scope for the potential and worthwhile expansion of the parallel use of suitable frequency bands by means of CR and SDR. It is neither necessary nor advantageous to modify the Radio Regulations for the use of CR and SDR.
2. ITU-R recommendations would be advantageous for fostering the broadest possible worldwide markets:
 - a. The relevant study groups could develop recommendations for the use of SDR and CR in applications and their impact on the services within their scope of responsibility.
 - b. With regard to vertical sharing, the relevant study groups could develop recommendations based on CR technology for the protection of the services within their scope of responsibility against other services.
 - c. Study Group 1 could amend ITU-R Recommendation SM.1538 (Short Range Devices) to include the appropriate applications and their corresponding parameters.
 - d. If necessary, the relevant study groups could formulate recommendations for CPC parameters if future technological developments indicate a need for this.
3. Nevertheless, it would be desirable to implement frequency policy measures at other levels. For example, an ECC recommendation or an ECC decision could encourage the use of CR technology for short range devices in order to achieve more efficient spectrum usage (such as in the 2.4–2.483 GHz band).
4. Fundamentally, CR technology does not open up new frequency bands, but the bands already in use can be used more effectively in order to avoid spectrum bottlenecks. For example, using CR technology would be worthwhile for Programme Making and Special Events (PMSE) and for public mobile radio.

Annex 1

Examples of Devices Based on Software Defined Radio

Several devices that use software defined radio technology are described below as illustrative examples.

GNU Radio

GNU Radio [GNURADIO] is an open-source software defined radio project. It is based on the Universal Software Radio Peripheral hardware platform and turns every standard computer into an SDR device.

Functions are available for various purposes, such as filtering, interleaving, FFT, automatic gain control, modulation and demodulation. Several air interfaces, including IEEE 802.11 (WLAN), Bluetooth and GSM, are already available as full source code.

A DVB-T modulator has also been implemented with GNU Radio. More information on this is available at [SOFT_DVB].

Consumer electronics: Digital Radio Mondiale

The first software products for computer-based reception of Digital Radio Mondiale (DRM) signals appeared already during the trial operation phase of this system. There are two types of implementation. The first type shifts the signal to the frequency range of a standard sound card, which digitises the signal. Decoding is performed by PC software. An example of this type of implementation is DiRaBox [DIRABOX].

The second type of implementation uses an integrated mixer and an analogue to digital converter. The signal is fed directly into the PC in the form of digitised samples and processed further in the PC. An example of this is a construction kit from Elektor [ELEKTOR], which users can assemble themselves. The associated software (open-source) is available at [DREAM].

Examples in the amateur service

Software defined radio technology is already in widespread use in the amateur radio sector. Due to software implementation of the transmit and receive components, the transmit parameters can be modified dynamically with a high degree of flexibility. An example of this is the FlexRadio Flex-5000C [FLEX-RADIO], which contains a standard PC processor. This processor is controlled by a program (PowerSDR) running under Windows XP, which enables the configuration of numerous transmit and receive parameters.

Other examples of SDR applications for broadcast receivers

A variety of receiver modules, especially for mobile terminals and USB devices, have become commercially available as a result of the launch of various new systems (including T-DMB, DVB-T, DVB-H, DVB-SH, ISDB-T and ATSC) and the beneficial effects of an ongoing process of miniaturisation. The manufacturer DiBcom is known for this. In the DiBcom 7070 IC one-chip tuner [DIBCOM], the entire demodulation process is implemented on chip in microcode. This allows any type of signal to be demodulated if suitable source code is available.

Another example of SDR for a DVB-T/T-DMB tuner is the Mirics FlexiTV product [MIRICS]. The signal is first filtered in the hardware components and then mixed down to baseband. Demodulation is performed in baseband by PC software after analogue to digital conversion. There are several bandwidth restrictions; a fixed bandwidth is specified for each available frequency band.

Annex 2

Potential Hazards of Air Interface Reconfiguration

To enable the reconfiguration of an SDR device, it is necessary to provide an additional interface between the hardware components and the software components for updating the device functions. In addition to changing the waveform of the electromagnetic signal, this interface can be used to change from one frequency band to another one (i.e. for rapid device optimisation).

This interface (or set of interfaces) may involve the same functions as those used to implement the observation and orientation elements of cognition with CR devices.

It must be insured that this interface and the downloadable software cannot be manipulated by external parties. Access to this interface for software updating must therefore be secured appropriately. Software updating does not occur while the air interface is in use. The new software is first downloaded, the air interface is disabled, the software is installed, and then the air interface is re-enabled. This procedure is commonly used in scenarios such as updating the operating systems of mobile telephones.

Reconfiguration capability, and in particular the ability to select different frequency bands, gives rise to issues concerning liability and conformity.

Reconfiguration enables a hardware manufacturer or a network operator to market several different products with the same hardware that are able to use the frequency spectrum differently. Another option is to use software with the same functionality in different hardware models.

It may be possible for users to procure the hardware and the software that determine the properties of the air interface separately in order to install the desired (or necessary) software in the hardware, or it may be possible to download new software automatically without any direct involvement of the user. A prerequisite for this is that the devices are able to communicate with a suitable infrastructure over an additional interface. Although this offers extensive opportunities for competition between various providers, in this situation the question of responsibility or liability in case of misuse is unresolved.

Software that leads to non-conforming operation of the device could be downloaded over this interface. Here it is necessary to distinguish between various cases, since this could:

- occur with the intention of generating an interference signal;
- involve defective software, for example as a result of data degeneration;
- involve the wrong software version, which gives rise to incompatibilities.

These considerations lead to the realisation that issues related to safety and security must be resolved in order to protect users.

However, the present frequency regulation system does not have any procedure governing software updating. Such a procedure would first need to be created.

Issues concerning monopoly and competition may also arise.

However, both of these issues are well outside the scope of this study.

Annex 3

Examples of Precognitive Systems

Some examples of precognitive techniques are described below.

‘Listen before talk’ (LBT) and ‘detect and avoid’ (DAA)

‘Listen before talk’, sometimes called ‘listen before transmit’, and ‘detect and avoid’ are being used increasingly with short range devices. They yield higher spectral efficiency as a result of better interference avoidance in comparison to a rigid, non-cognitive transmission scheme (duty cycle or simply transmitting).

ETSI defines ‘listen before talk’ as follows [ETSI_LBT]:

‘performance requirement, usually in the form of a protocol, that requires a communications system to determine if the channel it intends to communicate in is occupied by another user and select from the available spectrum a channel for communication that reduces, to the extent possible, the potential for interference to/from another user of the spectrum.’

Listen before talk is therefore a technique in which a receiver listens for a defined period before deciding whether a channel is free. If it is not free, the device waits until it is free and then starts transmitting on this channel. This reduces the probability of interference.

DAA and LBT for short range devices

DAA and LBT are being used increasingly in low power devices. CEPT Recommendation 70-03 on short range devices [ECC_REC 70-03] provides an overview. The DAA and LBT parameters of the individual applications are largely defined directly in the ETSI standard.

One problem is that the devices do not constantly listen, so only a limited detection time is available. Depending on the transmit time (duty cycle or time-limited transmission), there is only a certain probability of detecting other activities. Another factor is that the hidden node problem occurs here as well.

DAA for ultra wideband

The introduction of ultra wideband technology is intended to occur within the scope of responsibility of the CEPT based on ‘detect and avoid’. The detection requirements are specified in ECC Report 120 [ECC-Report120]. They stipulate that a detection probability (the likelihood that a signal that is present is sensed) of at least 95% should be achieved.

Dynamic frequency selection (DFS) and dynamic channel allocation (DCA)

Like DAA, dynamic frequency selection can be regarded as a combination of listen before talk and frequency agility, which means that the signals of other users are detected in order to avoid interference and the frequency is adjusted dynamically if necessary in order to mitigate interference. This technique is used successfully for RLAN at 5 GHz in coexistence with radar systems.

Annex 4

Example Derivation of the Technical Constraints for the Use of Cognitive Radio Technology with Vertical Sharing

The constraints that must be satisfied when cognitive technology is used are described in a general form in **Sections 3.2.2** and **3.2.3**. Here a detailed derivation of these technical constraints is presented for the case of vertical sharing as an example.

Among other things, we explain the 'hidden node' problem, present a method for determining the minimum sensitivity of a CR device, analyse the various forms of potential interference under small-signal and large-signal conditions, describe how to determine the maximum power level for CR devices, and explain the impact of these considerations on the specific embodiment of the various elements of CR cognition.

For this example we choose the 470–790 MHz band, which is used on a primary basis by the broadcasting service and additionally on a secondary basis by PMSE applications. This means that in this example, we assume that PMSE application will employ CR technology in the future and will have a vertical sharing relationship with the broadcasting service. However, the derivation of the technical constraints has been kept as general as possible, so it also applies to other applications using CR technology in vertical sharing relationship.

Spectrum usage by CR devices is not allowed to cause any resource restrictions or any usage restrictions on or interference to the reception functions of existing and future spectrum users operating on any basis (primary or secondary).

To ensure the protection of primary radio services operating in the 470–790 MHz band (terrestrial television, usually DVB-T), the CR devices (also known as 'white space devices' (WSDs) in the 470 – 790 MHz band) must comply with specific technical and regulatory constraints. This means that the devices must first have the technical capability to identify the DVB-T service environment. Only after this is assured is it possible to specify a maximum allowable interference level within a regulatory context.

The classifications of the DVB-T service areas depend on the reception situation. Three planning configurations are distinguished in GE06:

- FX (Fixed Reception): a rooftop reception area in which the remote signal can be received by a directional antenna at a height of 10 m.
- PO (Portable Outdoor): a service area in which the television signal can be received outdoors with a portable device at a height of 1.5 m.
- PI (Portable Indoor): a service area in which the television signal can be received inside buildings using an indoor antenna at a height of 1.5 m.

In this connection, the service areas are planned using the parameters listed in **Table A4.1**.

	Fixed	Portable Outdoor	Portable Indoor
Reference frequency	650 MHz	650 MHz	650 MHz
Bandwidth	8 MHz (7.61 MHz)	8 MHz (7.61 MHz)	8 MHz (7.61 MHz)
Receiver noise figure	7 dB	7 dB	7 dB
Receiver C/N	21 dB	19 dB	17 dB
Receiver sensitivity	-77.2 dBm	-79.2 dBm	-81.2 dBm
Receive antenna gain	12 dBd	0 dBd	0 dBd
Receive antenna feeder loss	5 dB	0 dB	0 dB
Receive antenna height	10 m	1.5 m	1.5 m
Reference location probability	95%	95%	95%
Standard deviation used for the outdoor field strength variation	5.5 dB	5.5 dB	5.5 dB
Reference (Emed)ref at fr = 650 MHz	56 dB(μ V/m)	78 dB(μ V/m)	88 dB(μ V/m)
Height loss (10 m \rightarrow 1.5 m)		18 dB	18 dB
Median building penetration			8 dB
Standard deviation of the building penetration loss			5.5 dB
Combined location standard deviation			7.8 dB

Table A4.1: DVB-T planning parameters for the 470–790 MHz band according to GE06

For each combination of receiver sensitivity and reference field strength listed in Table A4.1, it is assumed that reliable DVB-T reception is possible at 95% of all locations.¹⁶

Two methods must be considered for the unambiguous identification of a DVB-T service environment:

- Sensing: the CR device independently detects spectrum occupancy by DVB-T and deduces the necessary protection.
- Geo-localisation using databases: the CR device knows its geographic position from data provided by a built-in GPS receiver, and it accesses a database to determine the current DVB-T service situation.

The technical requirements on the CR device with regard to the detection of a DVB-T signal are derived below. The decisive factor here is the minimum sensitivity that a CR device must have in order to ensure reliable identification of an existing DVB-T service area.

Observation of the radio environment

Before a CR device occupies a frequency, it must be ensured that this frequency may actually be used. A detection reliability of 99% to 99.9% is commonly mentioned for CR devices. A detection probability of 99% is assumed for the following analysis. If we assume that the CR

¹⁶ For rooftop reception this means (for example) that in at least 95% of all locations, a receiver connected to a rooftop receive antenna must be able to receive a signal having a mean reference field strength (E_{mean}) 56 dB μ V/m or more, which corresponds to power level at the receiver input ($P_{\text{in},95}$) of -77 dBm.

device and the DVB-T receiver have the same reception situation, in order to achieve this, the CR device must have a receiver sensitivity of

$$P_{\text{sens},99,\text{WSD}} = P_{\text{sens},95} + \mu(95) \cdot \sigma_F - \mu(99) \cdot \sigma_F = -81 \text{ dBm}$$

(see **Table A4.2** for values and an explanation of the formula).

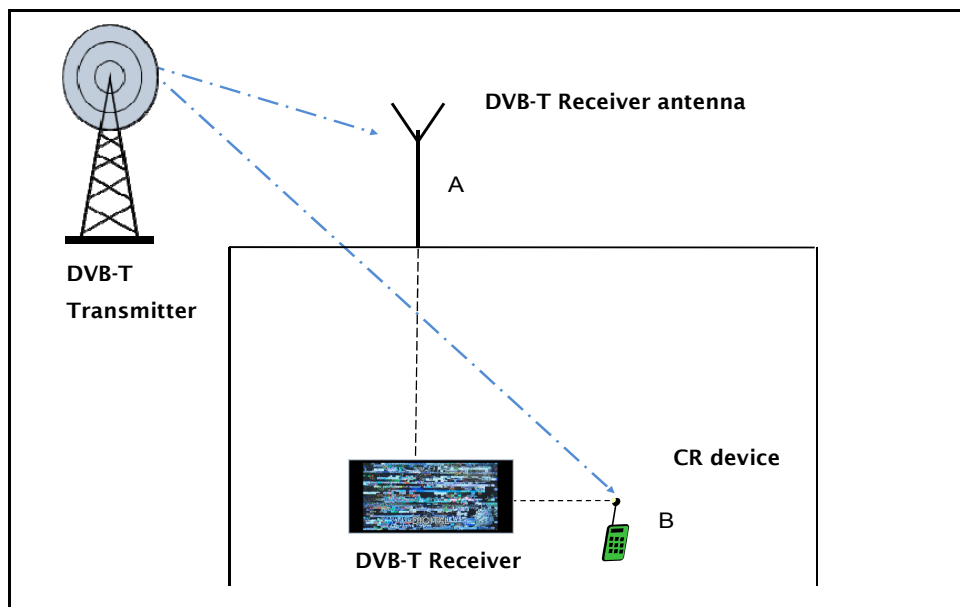

Figure A4.1: The hidden node problem arises from the difference between reception situation A (DVB-T rooftop reception) and reception situation B (CR indoor reception)

However, in most cases the CR receiver is located elsewhere in a different reception situation. For the CR device to nevertheless be able detect the DVB-T service, it must have a higher receiver sensitivity than the DVB-T receiver. This difference is called the hidden node margin (HNM), and it must be taken into account in the calculation of the required minimum sensitivity of the CR device. **Figure A4.1** shows an example of this sort of arrangement.

Calculation of the minimum sensitivity of a CR device				
Minimum DVB-T receiver sensitivity for FX		$P_{\text{sens},95}$	-77.2	dBm
Standard deviation indoors ($\sigma_F = \sigma_B = 5.5 \text{ dB}$, $\sigma_R = 3.5 \text{ dB}$)		$\sigma_i = \text{sqrt}(\sigma_F^2 + \sigma_B^2 + \sigma_R^2)$	8.53	dB
Factor for 95% DP		$\mu(95)$	1.64	dBm
Factor for 99% DP		$\mu(99)$	2.33	
Building penetration loss		BPL	8	dB
Height correction (from 10 m to 1.5 m)		H	18	dB
Antenna gain		G_A	12	dBd
Feeder loss		F	5	dB
Equivalent 50% value outdoors at 10 m		$P_{\text{sens},50}$	-68.18	dBm
Equivalent 99% value indoors at 1.5 m		$P_{\text{sens},99}$	-121.05	dBm
DVB-T signal 3 dB above noise		PM	3	dB
Modem	Body loss	BL	0	dB
	Antenna gain	G_M	-2.15	dBd
Required modem sensitivity		$P_{\text{sens},99,M}$	-120.20	dBm

Hidden node loss		$H_{99,M}$	43,0	dB
Handheld	Body loss	BL	3	dB
	Antenna gain	G_H	-12.25	dBd
Required handheld sensitivity		$P_{sens,99,H}$	-133.3	dBm
Hidden node loss		$H_{99,H}$	58.25	dB

Table A4.2: Parameters for calculating the minimum sensitivity of a CR device

The HNM value is given by the losses (propagation loss and building penetration loss) and the detection probability. With statistical values, the standard deviation of the signal must also be taken into account. Inside a building, this consists of the standard deviation of the outdoor field strength, the standard deviation of the building penetration loss, and the Rayleigh fading. Rayleigh fading relates to the probability of being located in a ‘DVB-T radio hole’¹⁷ resulting from the destructive interference of different waves, where the signal cannot be detected (‘fast fading’; see **Section 3.2.2.1**).

With a CR terminal (handheld), a body loss of 3 dB and a negative antenna gain of 10 dB must also be included.

It should be assumed that television programmes will not always be viewed under the same conditions, so a mixed situation (rooftop reception for some programmes and portable indoor reception for other programmes) is most likely. For this reason, the worst case situation must be assumed. The highest sensitivity is therefore required when the CR device is located indoors and needs to detect a DVB-T signal with rooftop reception.

Calculation:

$$P_{sens,50} = P_{sens,95} + \mu(95) \cdot \sigma_F$$

$$P_{sens,99} = P_{sens,50} - BPL - H - G_A + F - \mu(99) \cdot \sigma_i$$

$$P_{sens,99,M} = P_{sens,99} + PM - BL - G_M$$

$$P_{sens,99,H} = P_{sens,99} + PM - BL - G_H$$

For reliable detection of channel occupancy by a DVB-T signal, the sensitivity of a handheld CR device must be less than -133.3 dBm and the sensitivity of a CR modem must be better than -120.20 dBm.

For comparison, the thermal noise level of such a device can be assumed to be -100 dBm.¹⁸ This means that the CR device must be able to detect signals 33.3 dB or 20 dB below the noise level.

This assumes a field strength height correction factor of 18 dB, which applies to rural areas. The sensitivity threshold is even lower in a dense urban area (building height 30 m):

¹⁷ This rapid fading was assumed to be compensated by the diversity component in the GE06 planning parameters

¹⁸ With a noise figure of 5 dB and a bandwidth of 7.6 MHz.

$$P_{\text{sens}} = -133.3 \text{ dBm} - 10 \text{ dB} = -143.3 \text{ dBm},$$

which is 43.3 dB below the noise level.¹⁹

If these results are compared with the values mentioned in **Section 3.2.2**, it can be seen that only the sensitivity necessary for the rural area scenario with 99% detection probability could just about be achieved under laboratory conditions. Of course, this is not sufficient to ensure reliable minimisation of the probability of interference based on sensing alone.

It would be necessary to use a database or a CPC as well. The considerations and restrictions described in **Section 3.2.2** apply to these methods, with geo-localisation being the most economical option.

Technical constraints for the protection of the primary radio service

Next we investigate the maximum transmit power limit that must be imposed on a CR device in order to avoid co-channel, adjacent-channel and blocking²⁰ interference to the primary radio service (broadcasting service in this case) as much as possible. The calculation was performed for two different interference criteria:

(1) $I/N^{21} \leq -20 \text{ dB}$: The reference document here is ITU-R Recommendation BT.1786 [ITU-R BT.1786] for ultra wide band (UWB) devices, according to which the total interference from all interference sources is never allowed to exceed 1% of the noise power of the receiver. This corresponds to a maximum allowable I/N figure of -20 dB.

(2) $I/N = -10 \text{ dB}$: A maximum desensitisation (degraded C/N²² figure) of 0.5 dB for the DVB-T receiver is also commonly mentioned, which corresponds to a maximum I/N figure of -10 dB.

It is based on the parameters listed in **Table 4.3**.

Propagation model		Free space (< 1 km)	ITU-R Rec. P.1546 (≥1 km)
		Transmit antenna height	
		10 m	
Antenna gain (FX)	G_A [dB]		12
Feeder loss	F [dB]		5
Building penetration loss	BPL [dB]		8
Standard deviation of building penetration loss	σ_B		5.5

¹⁹ The required sensitivity threshold drops by an additional 6.5 dB for a detection probability of 99.9%, and in the worst case it may be

$$P_{\text{sens}} = -133.3 \text{ dBm} - 10 \text{ dB} - 6.5 \text{ dB} = -149.8 \text{ dBm},$$

which is 49.8 dB below the noise level.

²⁰ The blocking threshold is the maximum allowable power level of an interference signal at the input of a DVB-T receiver. The receiver enters the saturation region if this limit is exceeded. This interference is independent of the level of the useful signal.

²¹ I/N is the ratio of the interference signal to the noise power.

²² C/N is the ratio of the carrier signal to the noise power

Standard deviation of carrier field strength	σ_F	5.5
Standard deviation of interference field strength	σ_I	5.5
Interference criterion	IC [dB]	I/N \leq -10 / -20
Blocking threshold of DVB-T receiver	BT [dBm]	-20
Service criterion		Noise limiting

Table A4.3: Parameters for interference calculations

Blocking interference

Blocking occurs when a high frequency signal at the input of the DVB-T receiver cannot be filtered out adequately by a steep-edged filter before it reaches the preamplifier. Due to nonlinearities in the preamplifier characteristics, intermodulation products are generated at high interference levels, and they appear in the signal channel as interference frequencies. Interference of this sort cannot be countered by raising the level of the desired signal. The blocking threshold of a DVB-T receiver is approximately -20 dBm, so the interference level at the input to the receiver must be below this level. Based on this and the propagation loss, the maximum allowable power of the CR device can be calculated for various distances between the CR device and the DVB-T receiver.

The free space loss (FSL) can be calculated with the following formula:

$$\text{FSL [dB]} = 32.45 + 20 \log_{10}(f \text{ [MHz]}) + 20 \log_{10}(d \text{ [km]})$$

Interference criterion: interference level at DVB-T receiver \leq -20 dBm							
Distance between DVB-T receiver and CR device [m]	2.0	5.0	10.0	20.0	50.0	100.0	1000.0
CR device interferes with rooftop reception (without intervening wall)							
Propagation loss [dB] (free space)	34.7	42.7	48.7	54.7	62.7	68.7	88.7
Antenna gain [dB]	12	12	12	12	12	12	12
Feeder loss [dB]	5	5	5	5	5	5	5
$P_{\text{CR device,max,FX}}$ (EIRP) [dBm]	5.6	13.5	19.6	25.6	33.5	39.6	59.6
CR device interferes with rooftop reception (with intervening wall)							
$P_{\text{CR device,max,FX,BPL}}$ (EIRP) [dBm]	13.6	21.5	27.6	33.6	41.5	47.6	67.6
CR device interferes with a portable DVB-T device (without intervening wall)							
Propagation loss [dB] (free space)	34.7	42.7	48.7	54.	62.7	68.7	88.7
$P_{\text{CR device,max,PO}}$ (EIRP) [dBm]	12.6	20.5	26.6	32.6	40.5	46.6	66.6

CR device interferes with a portable DVB-T device (with intervening wall)							
$P_{\text{CR device,max,PO,BPL}}$ (EIRP) [dBm]	20.6	28.5	34.6	40.6	48.5	54.6	74.6

Table A4.4: Blocking thresholds of CR devices at various distances from a DVB-T receiver

The antenna gain and the feeder loss, which correspond to an interference signal attenuation of 7 dB, must also be included in the analysis of interference to DVB-T rooftop reception. In addition, an antenna gain (G_i) of 2.15 dBi must be included in the calculation if the power is referenced to a isotropic antenna (EIRP instead of ERP).

Table A4.4 shows the maximum allowable transmit power ($P_{\text{CR device,max}}$) of the CR device without blocking for various distances between the CR device and a DVB-T receiver ('exclusion zones').

If we stipulate that a distance of 1000 m must be maintained between the CR device and the DVB-T receiver or DVB-T receive antenna and that the CR device is located outdoors (e.g. a base station), the upper limit to the allowable power of the CR device is 59.6 dBm. However, in practice such a large distance between the CR device and the DVB-T receive antenna can only be achieved in rural areas, where in most cases DVB-T reception is only possible with a rooftop antenna.

With a portable CR device, it is entirely possible for a portable DVB-T receiver to be present within a radius less than 10 m, which means that the upper power limit lies between 20 and 30 dBm.

Co-channel interference

There are two interference criteria for the maximum allowable power of the CR device ($P_{\text{CR device,max}}$):

I/N ≤ -10 dB:

$$\begin{aligned}
 P_{\text{CR device,max,10}} &= \text{minimum sensitivity} - \text{PR} - 10 \text{ dB} + \text{propagation loss} \\
 &= (-98.2 \text{ dBm} + 21 \text{ dB}) - 18 \text{ dB} - 10 \text{ dB} + \text{propagation loss} \\
 &= -105.2 \text{ dBm} + \text{propagation loss}
 \end{aligned}$$

I/N ≤ -20 dB:

$$\begin{aligned}
 P_{\text{CR device,max,20}} &= \text{minimum sensitivity} - \text{PR} - 20 \text{ dB} + \text{propagation loss} \\
 &= (-98.2 \text{ dBm} + 21 \text{ dB}) - 18 \text{ dB} - 20 \text{ dB} + \text{propagation loss} \\
 &= -115.2 \text{ dBm} + \text{propagation loss}
 \end{aligned}$$

The maximum allowable transmit power of the CR device versus the distance to the DVB-T receiver is shown in **Figure A4.2** for $I/N \leq -10$ dB and in **Figure A4.3** for $I/N \leq -20$ dB for the co-channel interference scenario (blue line). Here it is assumed that the decoupling between

the CR device and the DVB-T receive antenna exposed to interference (polarisation decoupling, building penetration loss (if any) and diffraction loss) is 16 dB. This situation is typically present when the CR device is not located in the DVB-T service area.

The discontinuity in the blue curve results from the fact that the propagation model of ITU-R Recommendation P.1546 [ITU-R P.1546] is used in place of free-space propagation for distances greater than 1000 m. The limit lines shown in red result from the previously defined blocking thresholds for interference to DVB-T rooftop reception ($P_{CR\ device,max,FX}$) for the three exclusion zones (10, 100 and 1000 m) as listed in **Table A4.4**. The power of the CR device is limited by the blue line up to the point of intersection with the red line.

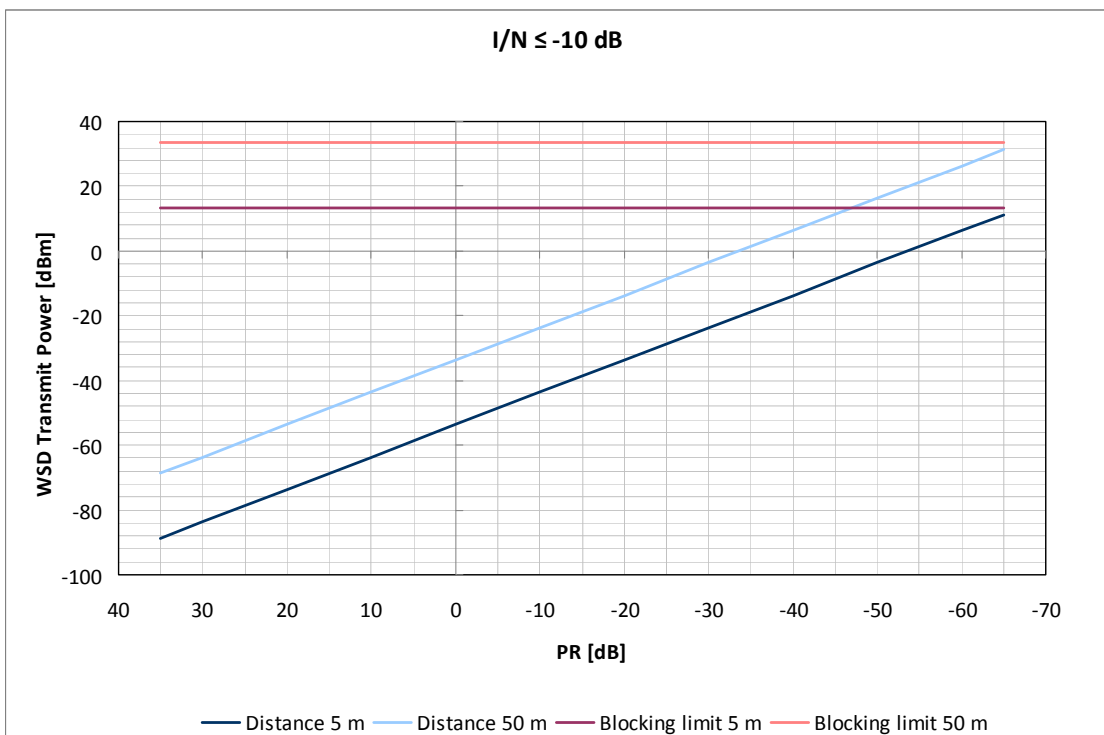

Figure A4.2: Maximum transmit power of a CR device versus distance to a DVB-T receiver for $I/N \leq -10$ dB (WSD = CR device, DTR = digital television receiver)

At larger distances between the DVB-T receiver and the CR device, higher power levels will not cause interference in the further reaches of the DVB-T service area in the case of co-channel operation, but they will cause blocking in the relevant exclusion zones.

For example, the transmit power is limited to 8 dBm with co-channel operation and a separation of 10 km. By contrast, a CR device transmit power of 20 dBm is allowable if blocking is the only interference mechanism present and a 10 m exclusion zone is assumed.

The blue line is 10 dB lower in **Figure A4.3** than in **Figure A4.2** because the criterion is taken to be $I/N \leq -20$ dB.

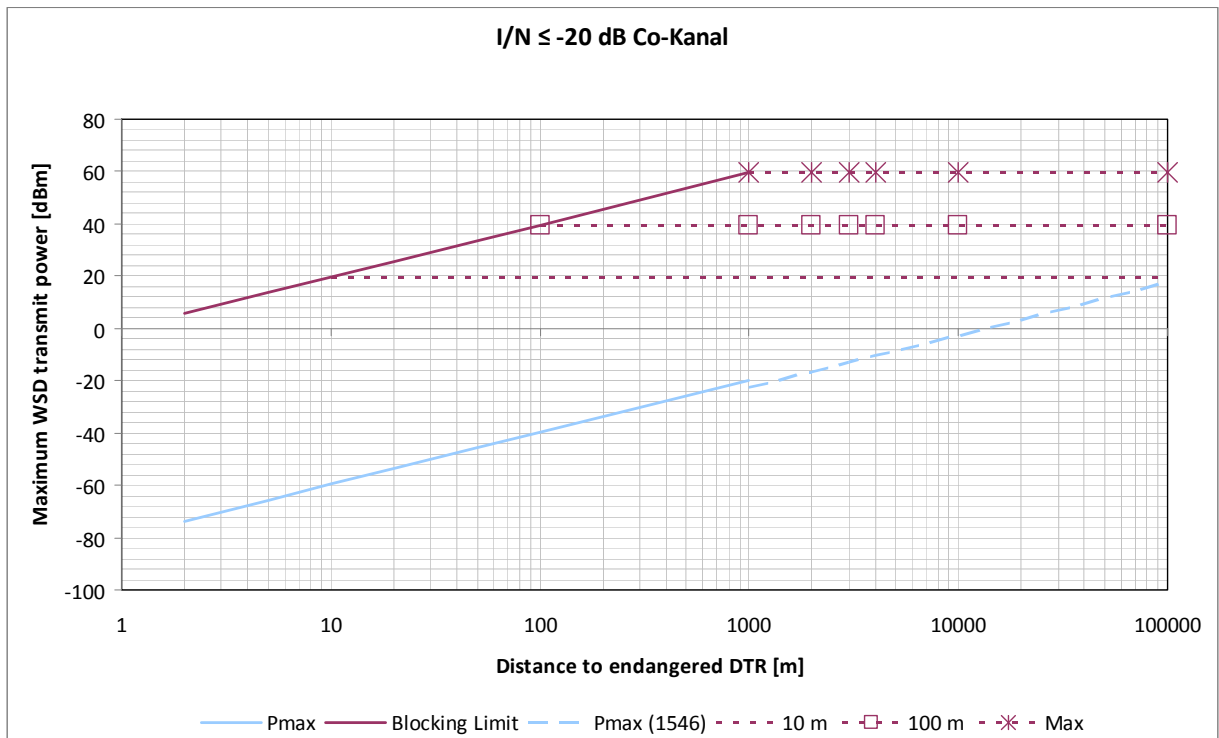

Figure A4.3: Maximum transmit power of a CR device versus distance to a DVB-T receiver for $I/N = -20$ dB (WSD = CR device, DTR = digital television receiver)

For the sake of completeness, we also examine the situation in which the DVB-T receive antenna is aimed directly at the CR device.

If the CR device is inside the DVB-T service area instead of outside this area, the antenna gain of the DVB-T antenna must also be included in the calculation. The difference between the two situations is 16 dB, as illustrated in **Figure A4.4**. The relationships shown in **Figures A4.2** and **A4.3** apply to situations where the CR device is outside the DVB-T service area. If the CR device is inside the DVB-T service area, the power limit is therefore 16 dB lower. From these graphs, it can be seen that the power limitations (-36 dBm at 1 km) practically exclude co-channel operation inside a DVB-T service area.

Adjacent-channel interference

In the case of adjacent-channel interference, the CR device is located in the DVB-T service area, so the antenna gain of the DVB-T receiver is included in the interference calculation for the DVB-T receiver. The maximum transmit power of the CR device depends on the protection ratio and a stipulated distance between the CR device and the DVB-T receiver (exclusion zone). **Figures A4.5** and **A4.6** show the maximum transmit power of the CR device versus the protection ratio for two exclusion zone sizes (5 m and 50 m). The power of the CR device is limited by the blocking threshold beyond the intersection of the red and blue lines.

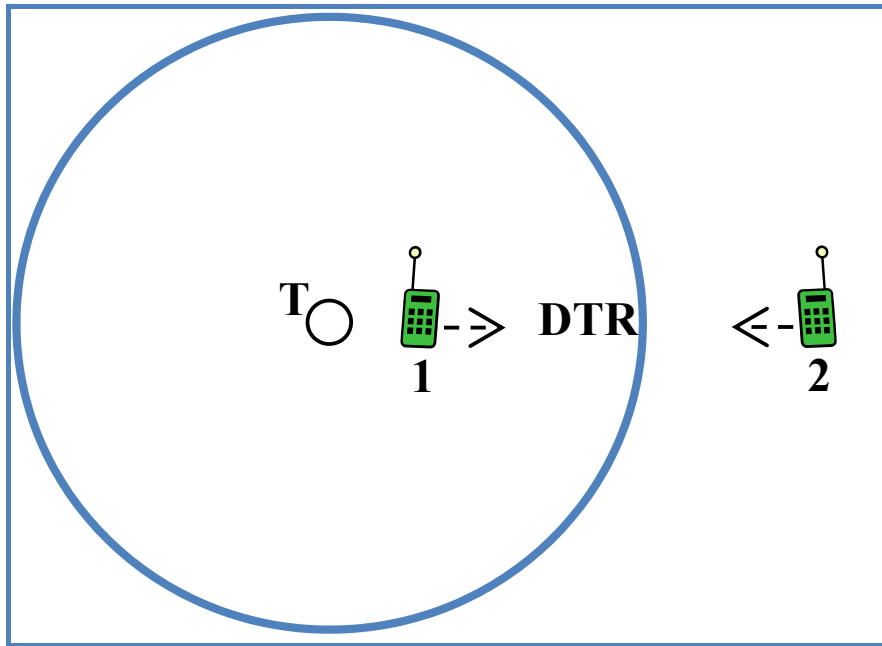

Figure A4.4: A CR device may be located either inside (1) or outside (2) the service area (DTR = digital television receiver)

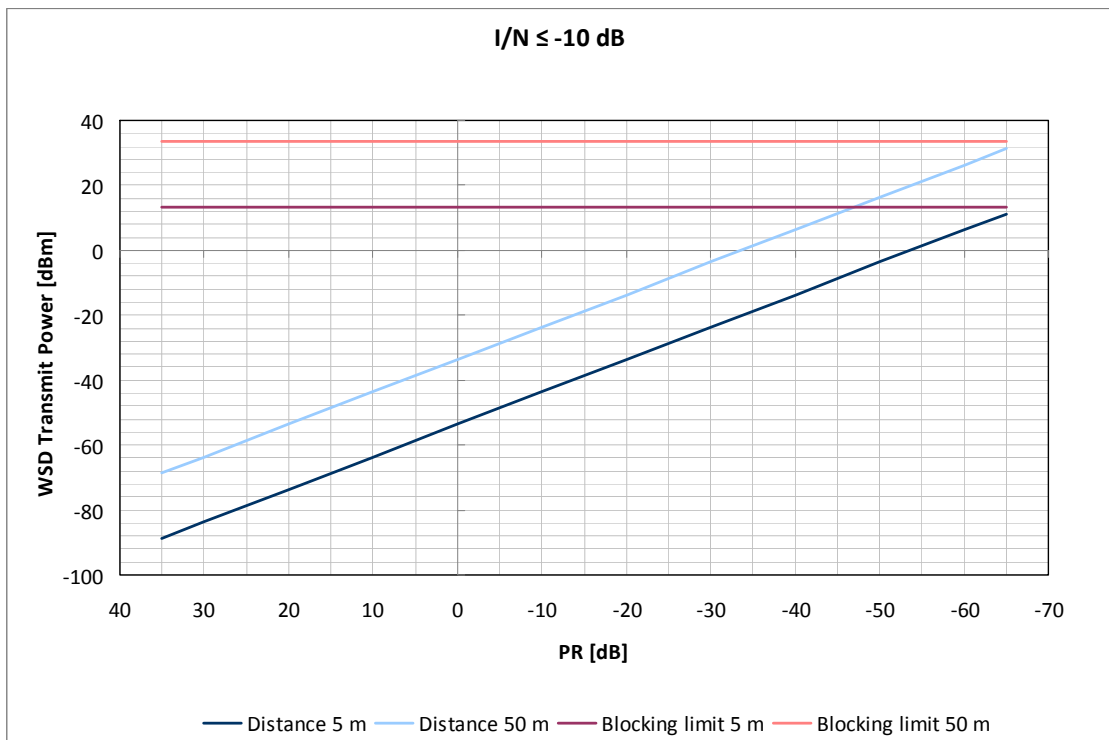

Figure A4.5: Maximum transmit power of a CR device versus distance to a DVB-T receiver for $I/N \leq -10$ dB (WSD = CR device)

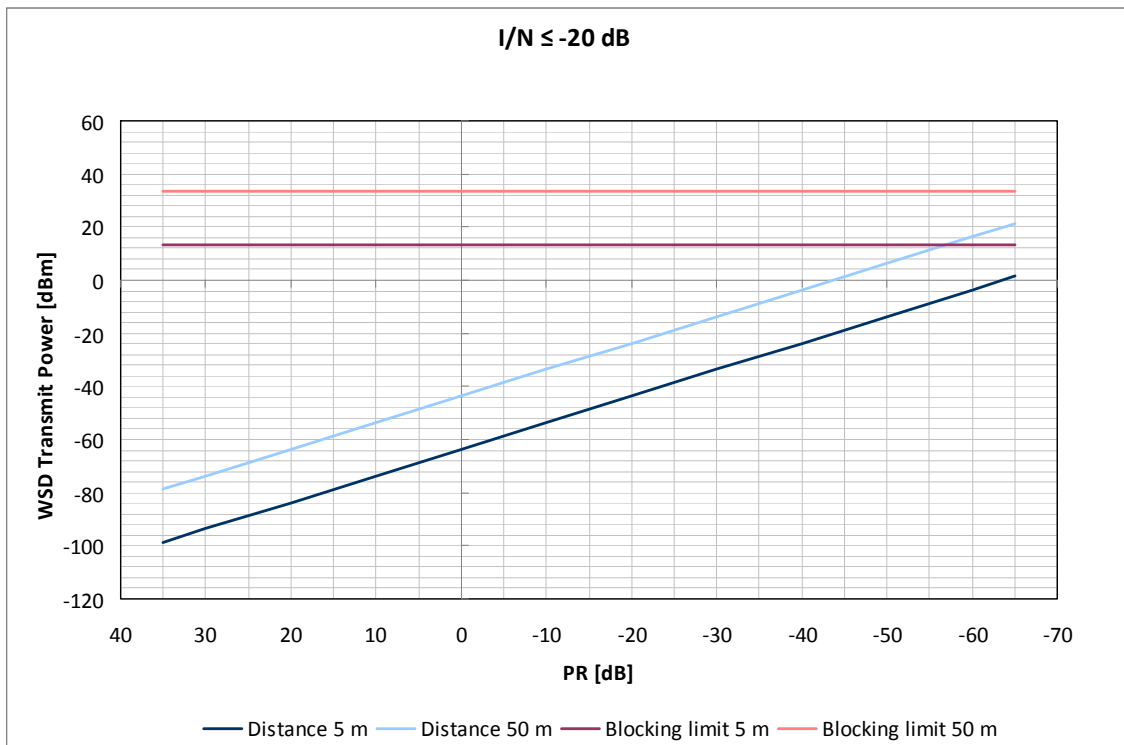

Figure A4.6: Maximum transmit power of a CR device versus distance to a DVB-T receiver for $I/N \leq -20$ dB (WSD = CR device)

For example, if we assume that a DVB-T receiver is located 5 m away from the CR device and a protection ratio of -30 dB applies to the channel, according to **Figure A4.6** the CR device may have a transmit power of approximately -24 dBm. The maximum transmit power with a distance of 5 m and sufficiently large frequency separation is determined by the blocking threshold limitation and is 13.5 dBm.

	0.5 m	2 m	5 m	10 m
Correction factor for distances other than 5 m between the CR device and the DVB-T receiver	-20 dB	-8 dB	-	+6 dB
There is a wall between the CR device and DVB-T receiver (loss 8 dB, standard deviation 5.5)	+4.3 dB			
The DVB-T signal is 10 dB above the noise level	+10 dB			
Interference to portable reception (no antenna gain)	+7 dB			

Table A4.5: Correction factors for maximum CR transmit power

These values apply to the scenario of interference to DVB-T rooftop reception from a CR device located outdoors. Other scenarios with corresponding correction factors can be derived using the data in the summary table (Table A4.5).

		I/N = -10 dB									
Distance between CR device and DVB-T receiver [m]		0.5	2	5	10	20	50	100	200	500	1000
Channel separation	PR ²³ [dB]										
N	18	-91.7	-79.6	-71.7	-65.6	-59.6	-51.7	-45.6	-39.6	-31.7	-25.6
N+1	-24	-49.7	-37.6	-29.7	-23.6	-17.6	-9.7	-3.6	2.4	10.3	16.4
N+2	-46	-27.7	-15.6	-7.7	-1.6	4.4	12.3	18.4	24.4	32.3	38.4
N+3	-51	-22.7	-10.6	-2.7	3.4	9.4	17.3	23.4	29.4	37.3	43.4
N+4	-59	-14.7	-2.6	5.3	11.4	17.4	25.3	31.4	37.4	45.3	51.4
N+5	-59	-14.7	-2.6	5.3	11.4	17.4	25.3	31.4	37.4	45.3	51.4
N+6	-62	-11.7	0.4	8.3	14.4	20.4	28.3	34.4	40.4	48.3	54.4
N+7	-60	-13.7	-1.6	6.3	12.4	18.4	26.3	32.4	38.4	46.3	52.4
N+8	-65	-8.7	3.4	11.3	17.4	23.4	31.3	37.4	43.4	51.3	57.4
N+9	-36	-37.7	-25.6	-17.7	-11.6	-5.6	2.3	8.4	14.4	22.3	28.4

Table A4.6: Maximum CR device transmit power for DVB-T rooftop reception with a 16 QAM DVB-T system and a maximum allowable I/N of -10 dB

²³ The protection ratio (PR) designates the signal to noise ratio

		I/N = -20 dB									
Distance between CR device and DVB-T receiver [m]		0.5	2	5	10	20	50	100	200	500	1000
Channel separation	PR[dB]										
N	18	-101.7	-89.6	-81.7	-75.6	-69.6	-61.7	-55.6	-49.6	-41.7	-35.6
N+1	-24	-59.7	-47.6	-39.7	-33.6	-27.6	-19.7	-13.6	-7.6	0.3	6.4
N+2	-46	-37.7	-25.6	-17.7	-11.6	-5.6	2.3	8.4	14.4	22.3	28.4
N+3	-51	-32.7	-20.6	-12.7	-6.6	-0.6	7.3	13.4	19.4	27.3	33.4
N+4	-59	-24.7	-12.6	-4.7	1.4	7.4	15.3	21.4	27.4	35.3	41.4
N+5	-59	-24.7	-12.6	-4.7	1.4	7.4	15.3	21.4	27.4	35.3	41.4
N+6	-62	-21.7	-9.6	-1.7	4.4	10.4	18.3	24.4	30.4	38.3	44.4
N+7	-60	-23.7	-11.6	-3.7	2.4	8.4	16.3	22.4	28.4	36.3	42.4
N+8	-65	-18.7	-6.6	1.3	7.4	13.4	21.3	27.4	33.4	41.3	47.4
N+9	-36	-47.7	-35.6	-27.7	-21.6	-15.6	-7.7	-1.6	4.4	12.3	18.4

Table A4.7: Maximum CR device transmit power for DVB-T rooftop reception with a 16 QAM DVB-T system and a maximum allowable I/N of -20 dB

For example, the maximum transmit power is -25 dBm (-24 dBm – 8 dB + 7 dB) for a portable CR device located 2 m away from a DVB-T receiver if we assume a protection ratio of -30 dB and an interference criterion of -10 dB.

Tables A4.6 and **A4.7** show potential transmit power limitations on CR devices for the protection of DVB-T rooftop reception. Here the protection ratios are taken from the draft version of ECC Report 148 [ECC-Report148], using a conversion factor of 4.3 dB for 64 QAM to 16 QAM.

Annex 5

Interference Mitigation Techniques

Techniques for interference mitigation are described in this annex. In combination with cognitive technology, they result in a significant reduction in the probability of interference.

Frequency hopping spread spectrum (FHSS)

With FHSS, the carrier frequency is constantly changed. Pseudo-random numbers determine the carrier frequency to be used at any given time. As a result, interference on a particular carrier frequency has only a short-term effect. In combination with error correction algorithms, the probability of interference is significantly reduced.

Direct sequence spread spectrum (DSSS)

With this technique, the data symbols are multiplied by a wideband pseudo-random code. Signals on the same frequency can be separated by using this specific code. This is utilised in military applications, and it forms the basis for UMTS. In the ideal case, all codes are perfectly orthogonal to each other, so no DSSS signal can cause interference to other DSSS signals. In practice, the interference level is at least reduced significantly.

Using DSSS also has a positive effect on applications coexisting with DSSS systems, since the spread signal has a much lower spectral power density than the unspread signal and therefore causes less interference to non-DSSS applications. This improvement comes at the expense of a larger bandwidth requirement.

Beam forming and advanced antenna technologies

Beam forming is the ability of an antenna to adapt its radiation characteristic by means of electronic circuitry. Multiple-array antennas are a known implementation. This technology can be used to suppress undesired signals or maximise the level of the desired signal. Using complex algorithms, the transmit and receive antennas can be optimally adapted to each other to maximise the transmission capacity. A basic issue here is whether sufficient computing capacity is available. In addition, the antenna elements must be implemented within constricted spaces. Fundamentally, with a constant form factor (predefined device dimensions) higher efficiency can be achieved at higher frequencies.

Annex 6

Discussion of the Technical Restrictions on Cognitive Radio

Introduction

CR and SDR devices will share the same frequency band with applications that do not use CR or SDR. Although this does give rise to any direct physical restrictions on CR and/or SDR systems, the physical restrictions for the other users, which are described below, form constraints for CR and SDR devices.

Selectivity of the coexisting services

A CR or SDR device that wishes to use the spectrum concerned must restrict its operation such that it does not cause additional interference, taking into account the selectivity of the existing devices. Every device has finite selectivity, which means that even if there is no overlap between the interference signal and the desired signal, the interference signal causes interference. This takes the form of adjacent-channel interference or saturation of the receiver amplifier.

Improved selectivity can be achieved with higher complexity, at corresponding cost and effort. Consequently, the scope of selectivity requirements is usually limited to what is actually necessary for the spectrum usage and interference scenarios. Stringent requirements may be specified when a new system is introduced, but the selectivity of existing applications is based on previous usage scenarios.

Electromagnetic shielding of devices

For cost and design reasons, devices are shielded only to the extent necessary to conform to the standards for compliance with the EMC Directive (see [EMC_DIRECTIVE]) and the relevant interference scenarios. Interference may occur if a CR device is operated in the vicinity of a device with limited shielding.

Near-far problem

The 'near-far' problem arises when an interference source is located close to a receiver that is intended to receive a signal from a transmitter located further away. If the interference signal cannot be suppressed adequately by filtering (or degradation), the dynamic range of the receiver must be sufficient to avoid saturation in this situation. If the receiver dynamic range of devices without CR or SDR is inadequate, the CR or SDR devices must take this into account by exercising additional restrictions (power restriction or exclusion of the frequencies concerned) on the use of adjacent channels.

Bibliography

- [ALM/ZAK] Kommission für Zulassung und Aufsicht (ZAK) der Landesmedienanstalten: Digitalisierungsbericht 2009, Vistas Verlag, Berlin, September 2009
- [ASSA] Astronomical Society of South Australia: Roberts' Radio Astronomy Projects – Direct Conversion Software Defined Receiver, Astronomical Society of South Australia, Adelaide, 2010
Link: <http://www.radio-assa.org.au/dcsdr>
- [BNetzA_TCAM1] Eiden, Klaus: Results 2003, Marktüberwachung für R&TTE Produkte bei der Regulierungsbehörde für Telekommunikation und Post, presentation to the ATRT annual meeting, Bundesnetzagentur, Mainz, November 2004
- [BNetzA_TCAM2] Winkelmann, Stephan: Marktüberwachung in Deutschland – Paneuropäische Marktaufsichtskampagnen, presentation to the R&TTE Directive Revisions workshop, Bundesnetzagentur, Mainz, May 2009
- [BNetzA744] Federal Agency for Electricity, Gas, Telecommunication, Post and Railways: Vfg. 41 /2001, Mitteilung über das Inverkehrbringen von Funkanlagen nach § 10 Absatz 4 des Gesetzes über Funkanlagen und Telekommunikationsendeinrichtungen (FTEG); specifically: Übersicht über die Geräte, die in die Klasse 1 entsprechend der Entscheidung der Kommission vom 6. April 2000 über die Festlegung einer vorläufigen Einstufung von Funkanlagen und Telekommunikationsendeinrichtungen (2000/299/EG) eingestuft worden sind, Bundesnetzagentur, Mainz, 2001
- [BOGERS] Bogers, Mark: R&TTE Review Surveillance aspects, presentation to the R&TTE Directive Revisions workshop, EU Commission, Mainz, May 2009
- [CEPT-Report22] CEPT: CEPT Report 22, Technical considerations regarding harmonisation options for the Digital Dividend – Technical Feasibility of Harmonising a Sub-band of Bands IV and V for Fixed/Mobile Applications (including uplinks), minimising the Impact on GE06, CEPT, July 2008
- [CEPT-Report29] CEPT: CEPT Report 029, Report from CEPT to the European Commission in response to the Mandate on Technical considerations regarding harmonisation options for the digital dividend in the European Union – Guideline on cross border coordination issues between mobile services in one country and broadcasting services in

- another country, CEPT, July 2009
- [DAA_PWMS_GROUP] PWMS Manufacturer's Group: DAA for PWMS operation in the 1.5 GHz MSS band – Input Document to ECC PT SE24, M46_29, Copenhagen, November 2008
- [DIBCOM] Pousset, Gerard: White paper no. 2, Evolution of DVB-T Front-end Receivers through integration, DiBcom, Paris, June 2007
Link: http://www.dibcom.info/Images/Upload/pdf/whitePaper2_integration_MD_V2.pdf
- [DIRABOX] Rudolf Ille Nachrichtentechnik: DRB 30 DiRaBox Digital Radio Box. product description, November 2009
Link: <http://www.nti-online.de/dirabox.htm>
- [DREAM] Dream DRM Receiver: Open-Source Software Implementation of a DRM, Sourceforge.net
Link: http://sourceforge.net/apps/mediawiki/drm/index.php?title=Main_Page
- [E2R-CPC] E2R: E2R II White Paper, The E2R II Flexible Spectrum Management (FSM) Framework and Cognitive Pilot Channel (CPC) Concept – Technical and Business Analysis and Recommendation, E2R, November 2007
- [EADS_SDR] Dingley, Peter, Sturman, Taj A, Bowyer, Mark DJ, Petfield, Neil: Multi Mode Radios – Their Role In Current and Future Communications, presentation to the IET Seminar on Military Satellite Communication Systems, EADS Astrium, June 2008
- [ECC-REC 70.03] CEPT: ERC Recommendation 70-03 (Tromsø 1997 and subsequent amendments) Relating to the Use of Short Range Devices (SRD); Recommendation adopted by the Frequency Management, Regulatory Affairs and Spectrum Engineering Working Groups, CEPT, Copenhagen, October 2009
- [ECC-Report82] CEPT: ECC Report 82, Compatibility study for UMTS operating within the GSM 900 and GSM 1800 frequency bands, ECC, Roskilde, May 2006
- [ECC-Report100] CEPT: ECC Report 100, Compatibility Studies in the Band 3400–3800 MHz between Broadband Wireless Access (BWA) Systems and Other Services, CEPT, Bern, February 2007
- [ECC-Report119] CEPT: ECC Report 119, Coexistence between Mobile Systems in the 2.6 GHz Frequency Band at the FDD/TDD Boundary, CEPT, Bern, February 2007

- [ECC-Report120] CEPT: ECC Report 120, Technical Requirements for UWB DAA (Detect and Avoid) Devices to ensure the Protection of Radiolocation Services in the bands 3.1–3.4 GHz and 8.5–9 GHz and BWA Terminals in the band 3.4–4.2 GHz, CEPT, Kristiansand, June 2008
- [ECC-Report121] CEPT: ECC Report 121, Compatibility Studies between Professional Wireless Microphone Systems (PWMS) and other services/systems in the bands 1452–1492 MHz, 1492–1530 MHz, 1533–1559 MHz also considering the services/systems in the adjacent bands (below 1452 MHz and above 1559 MHz), CEPT, Vilnius, September 2008
- [ECC_Report148] CEPT: Draft ECC Report 148, Measurements on the Performance of DVB-T Receivers in the Presence of Interference from the Mobile Service (Especially from LTE), CEPT, April 2010
- [ELEKTOR] Elektor: Software Defined Radio, *Elektor Electronics*, issue 365, May 2007, Elektor International Media
Link: <http://www.elektor.com/magazines/2007/may/software-defined-radio.91527.lynkx>
- [EMC_DIRECTIVE] European Parliament and European Commission: Directive 2004/108/EC of the European Parliament and of the Council, of 15 December 2004, on the approximation of the Laws of Member States relating to electromagnetic compatibility (EMC), European Parliament and European Commission, Brussels 2004
- [ERO_CLASS1] ERO: Indicative list of ‘Class-1’ equipment in accordance with the R&TTE Directive (1999/5/EC)
Link: <http://www.ero.dk/rtte>
- [ETSI_CPC] ETSI: Reconfigurable Radio Systems (RRS) – Cognitive Pilot Channel (CPC), ETSI TR 102 683 v1.1.1, Sophia Antipolis, September 2009
- [ETSI_DFS] ETSI: Broadband Radio Access Networks (BRAN) – 5 GHz high performance RLAN – Guide to the implementation of Dynamic Frequency Selection (DFS), ETSI TR 102 651, ETSI, Sophia Antipolis, June 2009
- [ETSI_LBT] ETSI: Electromagnetic compatibility and Radio spectrum Matters (ERM) – Short Range Devices (SRD) – Alternative Interference Mitigation Technologies to Listen Before Talk (LBT) for Ultra Low Power Active Medical Implants (ULP-AMI) operating from 403.5 MHz to 403.8 MHz with a duty cycle of less than or equal to 0.01%, System Reference Document ETSI TR 102 434, ETSI, Sophia Antipolis, June 2005

- [ETSI_SUMMARY] ETSI: Reconfigurable Radio Systems (RRS) – Summary of feasibility studies and potential standardization topics, ETSI TR ETSI TR 102 838, Sophia Antipolis, October 2009
- [FCC_USA] FCC: Second Report and Order and Memorandum Opinion and Order in the Matter of Unlicensed Operation in the TV Broadcast Bands Additional Spectrum for Unlicensed Devices Below 900 MHz and in the 3 GHz Band, FCC, Washington, November 2008
- [FCC_WHITE_SPACES] Technical Research Branch Laboratory Division, Office of Engineering and Technology, Federal Communications Commission: Initial Evaluation of the Performance of Prototype TV-Band White Space Devices, FCC, July 2007
- [FHG_SESSION2] Eberlein, Ernst: Tutorial on CRS/SDR, presentation to the workshop The Changing Regulatory and Evolutionary Environment and its impact on the Satellite Communication Business, Fraunhofer IIS Erlangen, September 2009
- [FLEX-RADIO] FlexRadio Systems: Flex 5000A Product Description, November 2009
Link: http://www.flex-radio.com/Products.aspx?topic=F5Ka_details
- [FreqBZPV] Bundesnetzagentur für Elektrizität, Telekommunikation, Post und Eisenbahnen: Frequenzbereichszuweisungsplanverordnung vom 28. September 2004 (BGBl. I S. 2499), die zuletzt durch die Verordnung vom 22. April 2010 (BGBl. I S. 446) geändert worden ist
Link: http://bundesrecht.juris.de/freqbzpv_2004/BJNR249900004.html
- [FreqNutz] Bundesnetzagentur für Elektrizität, Telekommunikation, Post und Eisenbahnen: Frequenznutzungsplan gemäß § 54 TKG über die Aufteilung des Frequenzbereichs von 9 kHz bis 275 GHz auf die Frequenznutzungen sowie über die Festlegungen für diese Frequenznutzungen, für Elektrizität, Gas, Telekommunikation, Post und Eisenbahnen, April 2008
http://www.bundesnetzagentur.de/cae/servlet/contentblob/38448/publicationFile/2659/Frequenznutzungsplan2008_Id17448pdf.pdf
- [GNURADIO] GNU Radio
Link: <http://gnuradio.org/redmine/projects/show/gnuradio>
- [HONG_CHEN] Hong, Xuemin, Chen, Zengmao, Wang, Cheng-Xiang, Vorobroy, Sergiy and Thompson, John: Interference cancellation for cognitive radio networks, *IEEE Vehicular Technology Magazine*, vol. 4, no. 4, November 2009.

- [HUAWEI_802.22] Lv, Linjun, Wu, Zhou, Jie, Mingwei, Zhang, Jianwei, Wang, Jun, Li, Shaoqian, Peng, Qihang, Chen, Lei and, Zeng, Meng: Sensing Scheme for DVB-T, contribution to *IEEE 802.22 WRAN Systems*, IEEE 802.22-05/0263r0, November 2006
Link: <https://mentor.ieee.org/802.22/dcn/06/22-06-0263-00-0000-huawei-sensing-scheme-for-dvb-t.doc>
- [ITU-R BT.1786] ITU: Recommendation BT.1786, Criterion to assess the impact of interference to the terrestrial broadcasting service (BS), ITU, Geneva, April 2007
- [ITU-R P.1546] ITU: Recommendation P.1546, Method for point-to-area predictions for terrestrial services in the frequency range 30 MHz to 3000 MHz, ITU, Geneva, October 2009
- [ITU-R WP5A] ITU: WP 5A Chairman's report, Working document towards a preliminary draft, new report ITU-R [LMS.CRS] – Cognitive radio systems in the land mobile service [411] Annex 21, ITU, Geneva, October 2009
- [ITU-R RA.769] ITU: Recommendation RA.769, Protection criteria used for radio astronomical measurements, ITU, Geneva, May 2003
- [ITU-R SM.2152] ITU: Report ITU-R SM.2152, Definitions of Software Defined Radio (SDR) and Cognitive Radio System (CRS), ITU, Geneva 20009
- [JALLON] Jallon, Pierre: A Detection Algorithm for the Identification of the Free Spectrum resources in DVB-T Bands, ICC 2008: 805–809
- [JANI] Ollikainen, Jani: Design and Implementation Techniques of Wideband Mobile Communication Antennas, Helsinki University of Technology Radio Laboratory Publications, Espoo, November 2004
- [Lokesh_Yadav] Tharani, Lokesh, Yadav, R.P.: Interference Reduction Technique in Multistage Multiuser Detector for DS-CDMA System, *International Journal of Electronics, Circuits and Systems* 2;4 © www.waset.org, fall 2008
Link: <http://www.waset.org/journals/ijecs/v2/v2-4-33.pdf>
- [MIRICS] Mirics DVB-T Receiver
Link: <http://www.mirics.com/products.php?navid=59>
- [MITOLA] Mitola, J., Maguire, G. Q. Jr.: Cognitive radio: Making software radios more personal, *IEEE Personal Commun. Mag.*, vol. 6, no. 4, pp. 13-18, Aug. 1999.
- [NSN_MULTIRADIO] Nokia Siemens Networks: Nokia Siemens Networks Flexi Multiradio BTS – data sheet, Nokia Siemens Networks

Link: http://w3.nokiasiemensnetworks.com/NR/rdonlyres/9DD8041D-DD13-424E-BDA2-6F034787D5D8/0/Flexi_multiradio_BTS_090202_intranet.pdf

[OFCOM_BAND] OFCOM: Digital Dividend Review: Band manager award – Licence fee receipts for spectrum used for programme-making and special events (2007–08), OFCOM, London, August 2007

Link: <http://www.ofcom.org.uk/consult/condocs/bandmgr/statement/statement.pdf>

[OFCOM_WSD] OFCOM: Digital Dividend: Cognitive access – Statement on licence-exempting cognitive devices using interleaved spectrum, OFCOM London, July 2009

<http://www.ofcom.org.uk/consult/condocs/cognitive/statement/>

[PRAESIDENTEN-KAMMER] Federal Agency for Electricity, Gas, Telecommunication, Post and Railways: Resolution of the President’s Chamber of the Federal Agency for Electricity, Gas, Telecommunication, Post and Railways of 12 October 2009 on combining the Award of spectrum in the 790 to 862 MHz, 1710 to 1725 MHz and 1805 to 1820 MHz, with proceedings to award spectrum in the bands 1.8 GHz, 2 GHz and 2.6 GHz for wireless access for the provision of telecommunication services, ref. BK 1a-09 /002, Bonn, October 2009

http://www.bundesnetzagentur.de/cln_1912/EN/Areas/Telecommunications/TelecomsRegulation/FrequencyManagement/FrequencyAward/frequencyAward_node.html

[PRAESIDENTEN-KAMMER1] Federal Agency for Electricity, Gas, Telecommunication, Post and Railways: Resolution of the President’s Chamber of the Bundesnetzagentur (BNetzA/Federal Agency for Electricity, Gas, Telecommunication, Post and Railways) on proceedings for the award of frequencies in the 3400 to 3600 MHz frequency band for Broadband Wireless Access (BWA), ref. BK 1-07 /009, Bonn, June 2008

http://www.bundesnetzagentur.de/cln_1912/EN/Areas/Telecommunications/TelecomsRegulation/FrequencyManagement/BroadbandWirelessAccess/broadbandwirelessaccess_node.html

[PUBLIC_SAFETY] FCC: 700 MHz Public Safety Spectrum, FCC, November 2009

Link: <http://www.fcc.gov/pshs/public-safety-spectrum/700-MHz/>

[R&TTE] European Parliament and European Commission: Directive 1999/5/EC of the European Parliament and of the Council of 9 March 1999 on radio equipment and telecommunications terminal equipment and the mutual recognition of their conformity, European Commission

and European Parliament, Brussels, March 2009

Link: <http://eur-lex.europa.eu/LexUriServ/LexUriServ.do?uri=CELEX:31999L0005:DE:HTML>

- [RS_SDR] Leschhorn, R., Buchin, B.: Military Software Defined Radios – Rohde & Schwarz status and perspectives, SDR Forum, technical conference, Phoenix, Arizona, USA, 15–17 November 2004
- [RSPG_STREAM] RPSG: Opinion on Streamlining the Regulatory Environment, RPSG, Brussels, November 2008
Link: http://rspg.groups.eu.int/_documents/documents/meeting/rspg17/rspg08246_finalopinion_streamlining.pdf
- [SCHRAM-MMN] Schramm, Raul: Ermittlung der rauschähnlichen Komponente des „Man-Made Noise“ bei 227 MHz aus mobilen T-DAB-Messungen, Technischer Blauer Bericht Nr. B 199/2007, IRT, Munich, 2007
- [SOFT_DVB] Pellegrini, Vincenzo, Bacci, Giacomo, Luise, Marco: Soft-DVB: A Fully-Software GNU Radio-based ETSI DVB-T Modulator, University of Pisa, Pisa 2008
- [SE43(10)40] Association of Professional Wireless Production Technologies: Chapter 5, Drafting, contribution to CEPT PT SE43, March, 2010
- [SPECTRUM] Spectrum: SDR 4000 Data Sheet
Link: http://www.spectrumsignal.com/products/pdf/sdr_4000.pdf
- [SUS] Kiencke, Uwe, Jäkel, Holger: *Signale und Systeme*, Oldenbourg Wissenschaftlicher Verlag; 3rd rev. & corr. edn, September 2005
- [TH-KARLSHRUHE] Koerner, Christian: Modelling the Spectral Occupation for the Use in Cognitive Radios, presentation to the Cognitive Radio – Technical Challenges and Commercial Implications workshop of VDE/ITG Technical Committee 5.2.4, TU Karlsruhe, Communications Engineering Lab – CEL, Hamburg, October 2009
- [TUB_MULTIHOP] Woesner, Hagen, Maier, Martin, Wolisz, Adam: Comparison of Single-Hop and Multihop WAG-Base WDM Networks, *Next Generation Optical Network Design and Modelling*, pp 51–65, Kluwer Academic Publishers, Berlin; 2003
- [VERFUEGUNG1_09] Federal Agency for Electricity, Gas, Telecommunication, Post and Railways: Frequency Allocation Procedure and Usage Conditions for Frequencies in the 3600 to 3800 MHz for the Implementation of Broadband Wireless Access (BWA) of 11 February 2009, Bonn, 2009
http://www.bundesnetzagentur.de/cln_1912/SharedDocs/Downloads/EN/BNetzA/Areas/Telecommunications/TelecomRegulation/Frequen

[cyManagement/AbIVfg1-2009Id15538pdf.html](http://www.bundesnetzagentur.de/cyManagement/AbIVfg1-2009Id15538pdf.html)

[VVRichtfunk]

Federal Agency for Electricity, Gas, Telecommunication, Post and Railways: Administrative Regulations for Frequency Assignments in the Fixed Service, Bonn, August 2004

Link: <http://www.bundesnetzagentur.de/cae/servlet/contentblob/38422/publicationFile/3091/FesterFunkdienstVVRichtfunkId586pdf.pdf>

[VVnömL]

Federal Agency for Electricity, Gas, Telecommunication, Post and Railways: Administrative Regulations for the Non-public Land Mobile Service, Bonn, March 2010

Link:

http://www.bundesnetzagentur.de/cae/servlet/contentblob/12998/publicationFile/3997/NichtOeffMobilLandFunkVVNoemL_Id18297pdf.pdf

List of Abbreviations

ADCO:	Group of Administrative Co-operation under R&TTE Directive 99/9
ASIC:	Application Specific Integrated Circuit
BEM:	Block Edge Mask
BOS:	Behörden und Organisationen mit Sicherheitsaufgaben (public safety agencies and organisations)
BWA:	Broadband Wireless Access
CDMA:	Code Division Multiple Access
CEPT:	Conférence Européenne des Postes et Télécommunications
CPC:	Cognitive Pilot Channel
CPU:	Central Processing Unit
CR:	Cognitive Radio
CRD:	Cognitive Radio Device
CRS:	Cognitive Radio System
CUS:	Collective Usage of Spectrum
DAA:	Detect And Avoid
DCA:	Dynamic Channel Allocation
DFS:	Dynamic Frequency Selection
DPMR:	Digital Private Mobile Radio
DRM:	Digital Radio Mondiale
DSP:	Digital Signal Processor
DSSS:	Direct Sequence Spread Spectrum
DVB-T:	Terrestrial Digital Video Broadcasting
DxB:	Digital x Broadcasting
EDGE:	Enhanced Data Rates for GSM Evolution
EFIS:	ERO Frequency Information System
EIRP:	Equivalent Isotropically Radiated Power
ENG/OB:	Electronic News Gathering / Outside Broadcast
ERP:	Equivalent Radiated Power
ETSI:	European Telecommunications Standard Institute

FHSS:	Frequency Hopping Spread Spectrum
FPGA:	Field Programmable Gate Array
FSL:	Free Space Loss
GE06:	Geneva 2006 Plan
GSM:	Global System for Mobile Communications
HF:	High Frequency
HNM:	Hidden Node Margin
HSPA:	High Speed Packet Access
ITU:	International Telecommunication Union
LBT:	Listen Before Talk / Listen Before Transmit
LTE:	Long Term Evolution
OFDM:	Orthogonal Frequency Division Multiplexing
PAMR:	Public Access Mobile Radio
PLD:	Programmable Logic Device
PMSE:	Programme Making and Special Events
PPDR:	Public Protection and Disaster Relief
PWMS	Professional Wireless Microphone System
R&TTE:	Radio & Telecommunications Terminal Equipment
RAT:	Radio Access Technology
RF:	Radio Frequency
RRC-06:	Regional Radiocommunication Conference 2006
RRS:	Radio Reconfigurable System
SFDR:	Spurious-Free Dynamic Range
SDR:	Software Defined Radio
SNR:	Signal to Noise Ratio
SIMD:	Single Instruction Multiple Data
SRD:	Short Range Device
T-DAB:	Terrestrial Digital Audio Broadcasting
TCAM:	Telecommunications Conformity Assessment and Market Surveillance Committee

UMTS: Universal Mobile Telecommunication System
UWB: Ultra Wide Band
WCDMA: Wideband Code Division Multiple Access
WGFM: Working Group Frequency Management
WGSE: Working Group Spectrum Engineering
WSD: White Space Device

- This page intentionally left blank -

- This page intentionally left blank -



Institut für Rundfunktechnik
Floriansmühlstraße 60
80939 Munich, Germany
www.irt.de
Tel. +49 (0) 89 | 323 99 - 300
Fax +49 (0) 89 | 323 99 - 200
marketing@irt.de

Registry Court of Munich, Entered in
Section B Vol. 65 No. 5191

© 2010 Institut für Rundfunktechnik GmbH. All rights reserved.